

WBP-LF

BED PLATE FOR WSG-LF GEARLESS LIFT MACHINE



Industrial



Residential



Office



Shopping



Hospital



Modernization

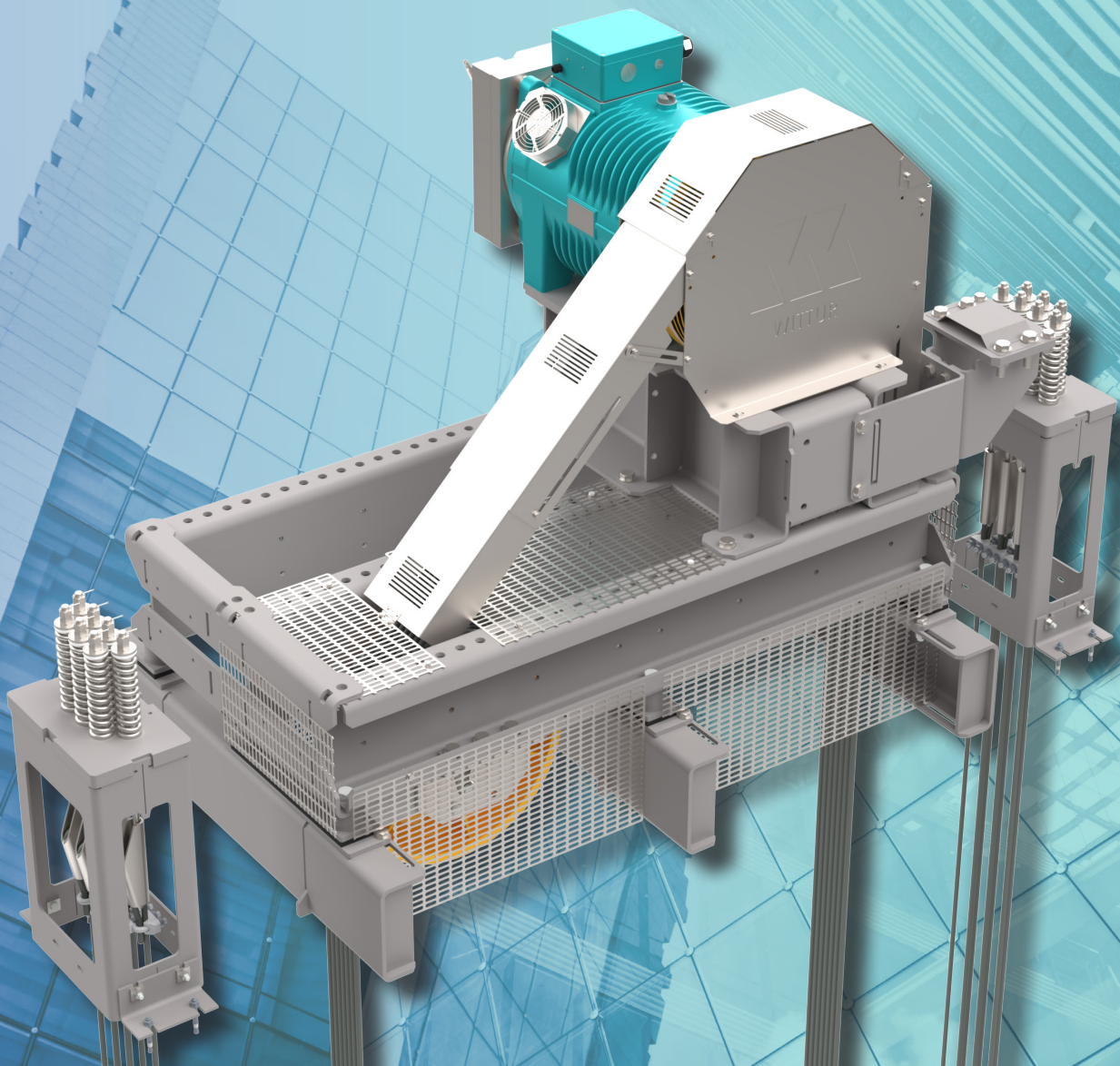

WBP-LF

Advantages

- Compatible with WSG-LF lift machines, slings and mechanical components
- Maximum space efficiency for new installations & modernizations
- Safe and adjustable rope guards and covers
- Unassembled light & compact delivered
- Modular ordering options depending on specific needs

Additional features

- Flexible high frame with deflection pulley
- 1:1 & 2:1 suspension
- Available deflection pulleys

	Material	øDL [mm]	max NR [-]	øDN [mm]	RP [mm]	øD [mm]	LA [mm]
Standard	Steel Pulley	10	7	410	16	65	105,4
		13	8	530	19	75	152
Optional	Steel Pulley	10	10	400	16	60	152
	Polyamid Pulley (plastic)	10	10	400	16	60	152
		13	8	530	19	75	152
	witout pulley witout rope guard	-	-	-	-	60	152
		-	-	-	-	75	152

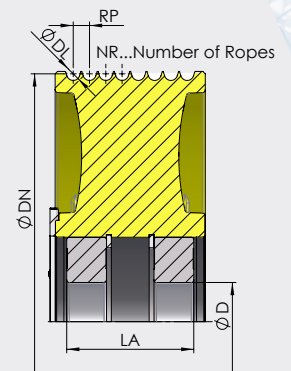

- Rated load acc. WSG-LF
- Rope downfall range (RD):

	1:1	2:1
max	1500 Kg	3000 kg

	RD(10) (10mm rope)	RD(13) (13mm rope)
max	440mm	550mm
min	1350mm	1400mm

Configurable Product (modules)

Minimum content

- M1) Lift machine table (riser)
- M2) Bed plate

Modularly expandable depending on specific needs:

- M3) Vibration dampers
- M4) Deflection pulley package
- M5) Cover
 - * M5.1) Traction sheave cover
 - * M5.2) Rope cover
 - * M5.3) Additional perforated sheets
- M6) Crosswise sheet metal beams
- M7) Adapter for mechanical rescue device
- M8) Rope fixing point (2:1)

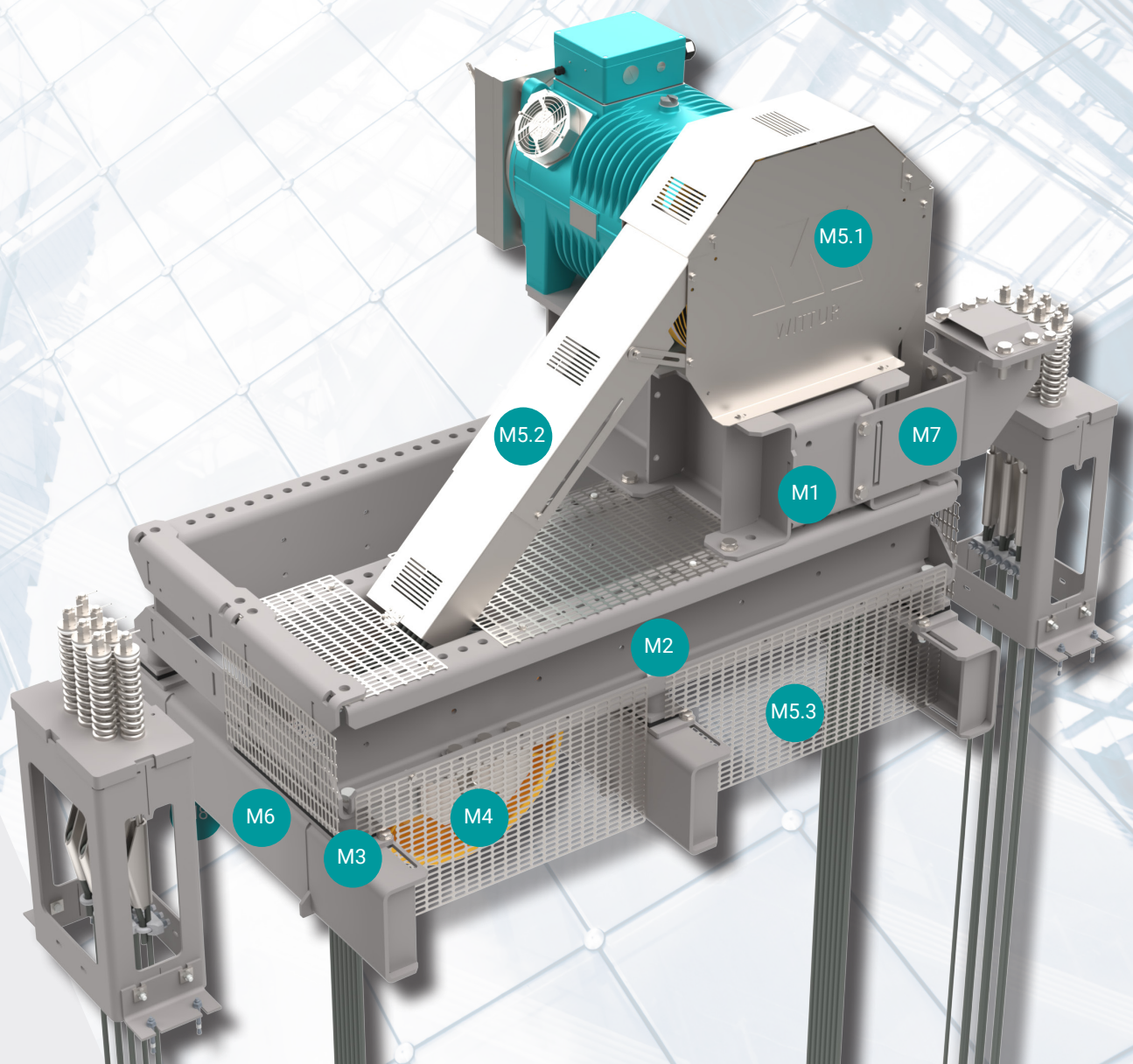

WBP-LF

Productoverview - Machine frame for WSG-LF.1/2/3/S

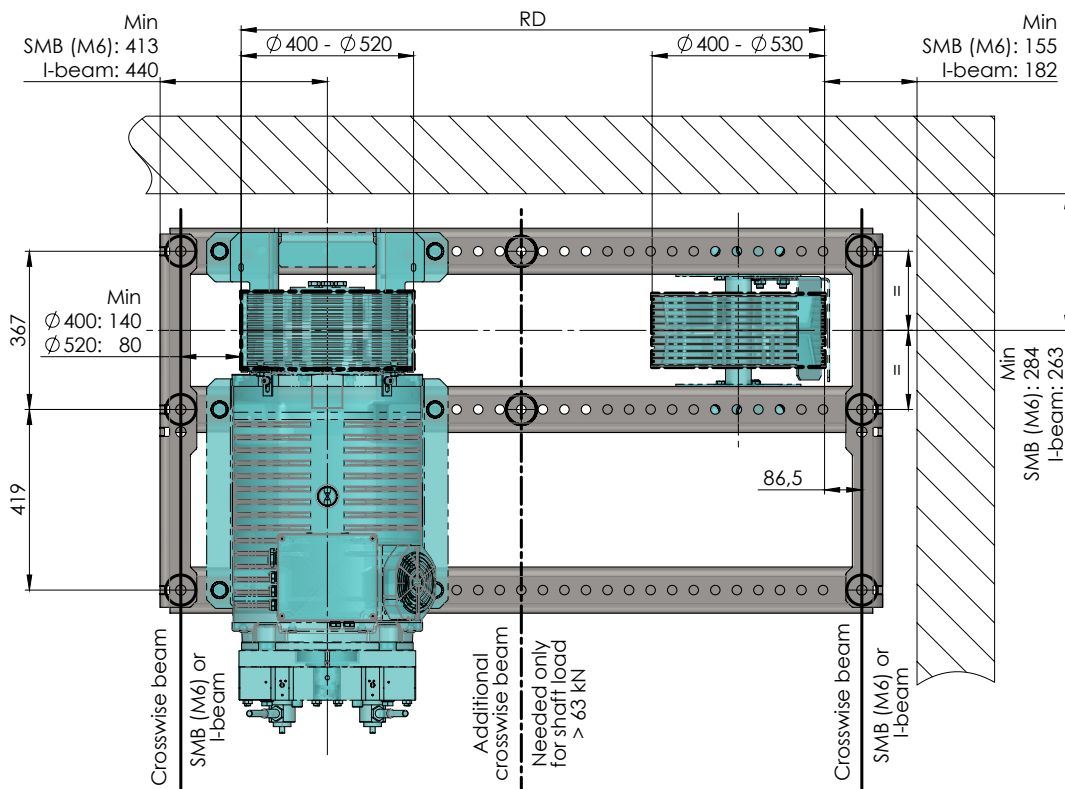
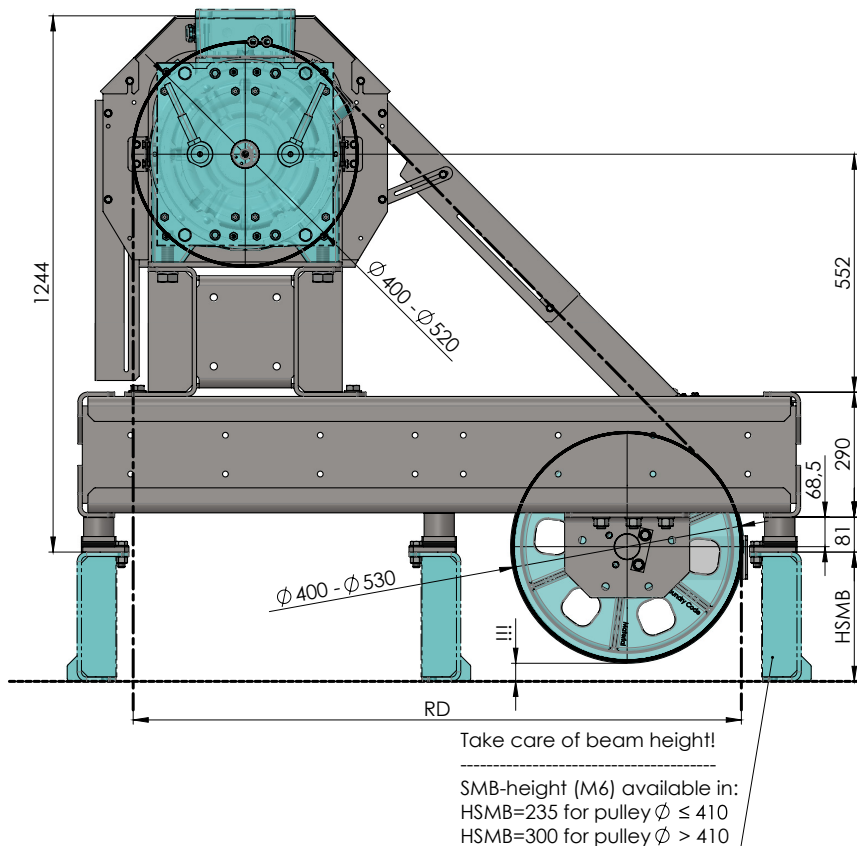

RD ... Rope downfall
 SMB ... Sheet metal beam (see M6)



WITTUR

YOUR GLOBAL PARTNER FOR COMPONENTS,
MODULES AND SYSTEMS IN THE ELEVATOR INDUSTRY



WITTUR.COM



WBP-SF/MF
on Wittur.com

ADVANCING THE ELEVATOR INDUSTRY®

WBP-SF - CSB 5.007637EN - English - March 2023

Subject to change without notice!