



WITTUR Electric
Drives GmbH



ANTRIEBSKULTUR AUS DRESDEN

SYNCHRON-SERVOMOTOREN

SYNCHRONOUS SERVOMOTORS

DUM 6
DUF 6

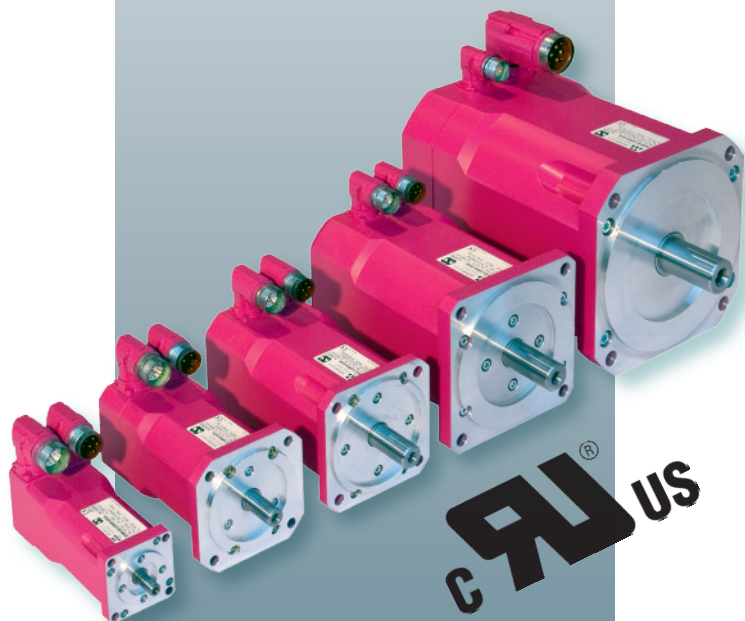

Hauptparameter

- hochdynamische 6 bzw. 8-polige permanent-erregte Synchronmotoren
- sinusförmig induzierte Spannung für exzellente Rundlaufeigenschaften
- maximale Impulsdrehmomente bis zum 3-fachen Stillstandsdauerdrehmoment des selbstgekühlten Motors
- Einsatz hochenergetischer Neodym-Eisen-Bor Magnete
- UL/CSA-Zulassung (UL-file Nummer E234973)
- bis Aufstellungshöhe 1000 m ü. NN keine Leistungsreduzierung
- vielfältige Optionen möglich (z. B. integrierte Haltebremse, Getriebeanbau, Sonderwelle, Temperaturfühler, Sonderflansch, Wicklungsvarianten, andere Mess-Systeme, elektronisches Typenschild)

	Standard	Option
Betriebsart	S1	
Schutzart	IP65	
Wellendurchführung	IP64	IP65
Schwingstärkestufe	B	
Flanschgenauigkeit	N	R
Isolierstoffklasse	155 (F) (Drahtisolation in Klasse 180 (H))	
Wicklungsschutz	Thermistor 150°C (mit verstärkter Isolation gemäß EN 50178)	KTY84; KTY83; Miniaturbimetallschalter; PT100
Leistungsanschluss	Stecker (drehbar, speedTEC-kompatibel)	
Gebersystemanschluss	Stecker (drehbar, speedTEC-kompatibel)	
Gebersystem	Resolver	Sin-Cos-Absolutwertgeber
Kühlung	Selbstkühlung	Fremdkühlung
Bremse	-	Haltebremse
Farbanstrich	RAL9005 (matt-schwarz)	Sonderfarben
Lager	Radialrillenkugellager mit Lebensdauerschmierung	
Wellenende	glattes Wellenende	Passfeder mit Halbkeilwuchtung
Umgebungstemperaturbereich	-15°C bis +40°C	

Main parameters

- Highly dynamic 6 or 8-pole permanent-field synchronous motors
- Sinusoidal induced voltage for excellent true running properties
- Maximum pulse torques up to 3fold continuous stall torque of self-cooled motor
- Use of high-energy neodymium-iron-boron magnets
- UL/CSA approval (UL-file number: E234973)
- At altitudes up to 1,000 m a.s.l. no power output reduction
- Various options available such as integrated holding brake, gear unit, special shaft, temperature sensors, special flange, winding variants, different measuring systems, electronic type label.

	Standard	Option
Duty type	S1	
Degree of protection	IP65	
Shaft exit	IP64	IP65
Vibrational severity	B	
Flange accuracy	N	R
Thermal class	155 (F) (wire insulation in class 180 (H))	
Winding protection	PTC thermistor 150°C (strengthened insulation according to EN 50178)	KTY84; KTY83; bimetallic-element miniature switch
Power connection	Plug connector (rotatable, speedTEC-compatible)	
Measuring system con.	Plug connector (rotatable, speedTEC-compatible)	
Measuring system	Resolver	Sin-Cos-absolute value encoder
Cooling	Self-cooling	Forced-air cooling
Brake	-	Holding brake
Paint finish	RAL9005 (dull black)	Other colours
Bearings	Life-lubricated radial deep-groove bearing	
Shaft end	plain shaft end	with keyway and balanced with a half-key
Ambient temperature	-15°C to +40°C	

z. B. / e. g. D U M 6 - A 1 - 2 0 R9 6 - 000 A

D U **B3** **Z1** - **B4** **Z3** - **X1** **X2** **X3** **X4** - **X5** **X7**

B3: Bauform / Kühlart
Construction type / cooling method

- M - Flansch, Selbstkühlung
flange, self-cooling
- F - Flansch, Fremdkühlung
flange, forced-air cooling

Z1: Reihe / Series

- 6- Synchron / *Synchronous*

Z2: Einbaufenster / Mounting window

- A - 55 mm C - 95 mm E - 194 mm
- B - 75 mm D - 127 mm

Z3: Baulänge / Overall length

X1: Spannungsvariante / Voltage variant

- 2 - für Anschlussspannung U_N von 400 V
for supply voltages U_N from 400 V

X2: Haltebremse / Holding brake

- 0 - ohne / *no brake* 4 - mit / *with brake*

X3: Mess-Systemanbaumöglichkeit / Provision for measuring system

- Ax - Absolutwertgeber / *for absolute encoder systems*
- Ix - Inkrementalgeber / *for incremental encoder systems*
- Rx - Resolver (2, 6- oder 8-polig) / *for resolver (2, 6- or 8-pole type)*

X4: Bemessungsdrehzahl / Rated speed

- 0 - 1000 min⁻¹ 2 - 2000 min⁻¹ 4 - 4000 min⁻¹
- 1 - 1500 min⁻¹ 3 - 3000 min⁻¹ 6 - 6000 min⁻¹

X5: alphanumerische Kennzeichnung für Modifikationen

alphanumeric identifier for modifications

X7: Gebertyp (mit X3), Geberanschlussbelegung, und weitere kundenspez. Daten

Encoder type (together with X3), encoder pin assignment and other customer-specific data

DUM 6-Ax

- Mess-Systeme (X3):

AA AD 34 (Hengstler)
 IN ERN 1185 (Heidenhain)
 IW SKS/SKM 36 (SICK-Stegmann)
 R9 Resolver Size 15 (2-oder 6-polig)

- Measuring systems (X3):

AA AD 34 (Hengstler)
 IN ERN 1185 (Heidenhain)
 IW SKS/SKM 36 (SICK-Stegmann)
 R9 resolver size 15 (2- or 6-pole type)

X3= DUM 6-	ohne Bremse / without brake				mit Bremse / with brake			
	R9		AA / IN / IW		R9		AA / IN / IW	
	l ₃₈	r	l ₃₈	r	l ₃₈	r	l ₃₈	r
A 1	121	105	156	136	145	129	180	160
A 2	133	117	168	148	157	141	192	172
A 3	145	129	180	160	169	153	204	184
A 4	170	153	205	185	194	178	229	209

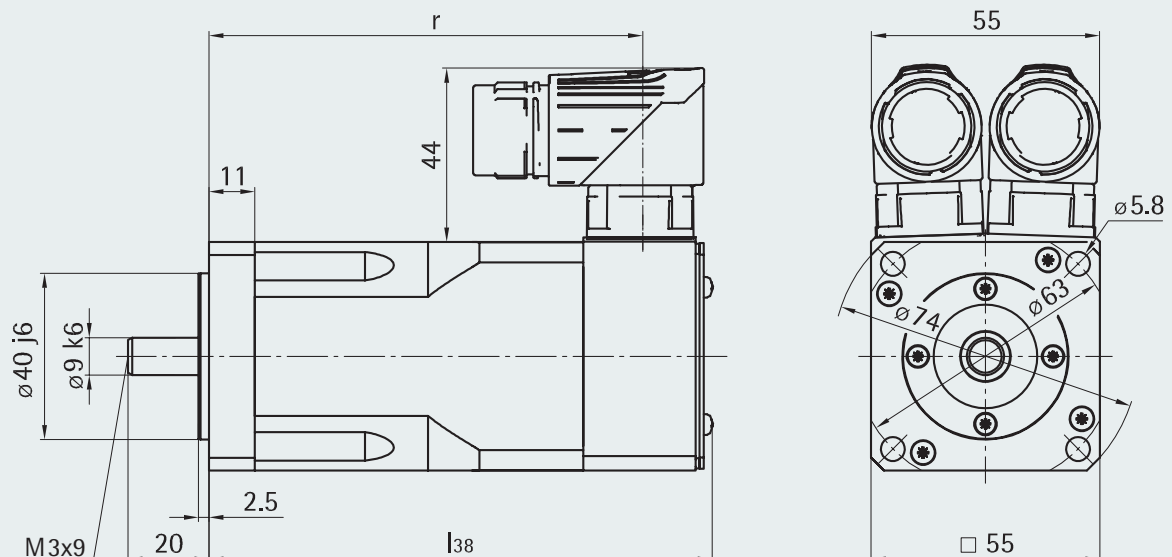

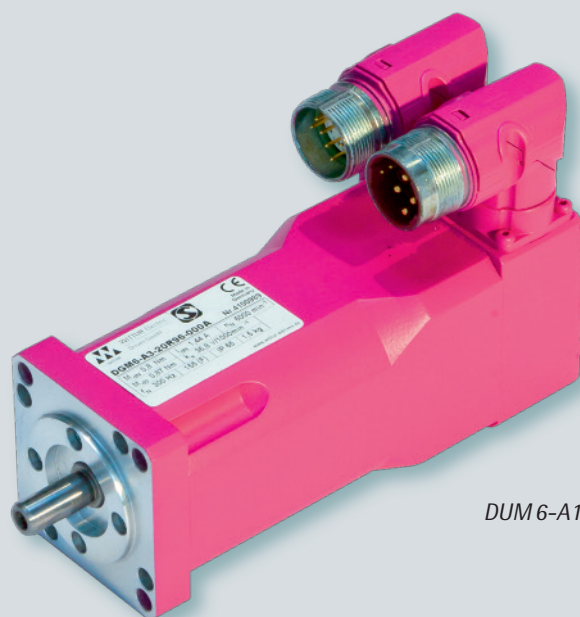

DUM6-A1

Haltebremse		Holding brake		
Haftmoment	M_{Br}	Nm	2,0	Holding torque
Bemessungsspannung	U_{Br}	V	24	Rated voltage
Bemessungsstrom (20°C)	I_{Br}	A	0,46	Rated current
Masse	m	kg	0,18	Weight
Läuferträgheitsmoment	J_{Br}	kgcm ²	0,07	Rotor inertia

¹⁾ betriebswarm, Effektivwert, verkettet

²⁾ bei 20°C

³⁾ mit Resolver Size 15 (X3=R9), ohne Haltebremse

¹⁾ at operating temperature, r.m.s. value, phase to phase

²⁾ at 20°C

³⁾ with resolver size 15 (X3=R9), without holding brake

Kenngröße	DUM 6				Parameters	
	- A1 -	- A2 -	- A3 -	- A4 -		
Einbaufenster, Baulänge Z2, Z3	2xx6	2xx6	2xx6	2xx6	Frame size, overall length	
Spannungs- u. Drehzahlvariante	2xx6	2xx6	2xx6	2xx6	Voltage and speed variant	
Stillstandsrehmoment	M_{d0} [Nm]	0,47	0,66	0,87	1,14	Stall torque
Stillstandsstrom	I_{d0} [A]	0,94	1,24	1,43	1,55	Current at stall torque
Stillstandsrehmoment	M_{d10} [Nm]	0,48	0,68	0,89	1,17	Stall torque
Stillstandsstrom	I_{d10} [A]	1,02	1,28	1,48	1,70	Current at stall torque
Polzahl	2p	6			Number of poles	
Bemessungsdaten					Nominal rating	
Bemessungsrehmoment	M_{dN} [Nm]	0,43	0,62	0,80	1,05	Rated torque
Bemessungsstrom	I_{dN} [A]	0,93	1,16	1,44	1,64	Rated current
Bemessungsdrehzahl	n_N [min ⁻¹]	6000	6000	6000	6000	Rated speed
Bemessungsleistung	P_{dN} [kW]	0,27	0,39	0,50	0,66	Rated power
Spannungskonstante ¹⁾	k_e [V/1000min ⁻¹]	31,2	34,1	36,8	41,5	Voltage constant ¹⁾
Wicklungswiderstand ²⁾	R_{u-v} [Ω]	37,4	24,0	17,8	12,6	Winding resistance ²⁾
Wicklungsinduktivität	L_{u-v} [mH]	19,0	13,1	11,5	9,6	Winding inductance
Maximalwerte					Max. values	
max. Drehmoment	M_{max} [Nm]	2,1	2,9	3,8	5,0	Max. torque
max. Strom (Scheitelwert)	I_{max} [A]	4,5	5,6	6,9	8,0	Max. current (peak value)
max. Drehzahl	n_{max} [min ⁻¹]	9000			Max. perm. speed	
mechan. Angaben ³⁾					Mechanical data ³⁾	
Läuferträgheitsmoment	J_L [kgcm ²]	0,13	0,18	0,23	0,34	Inertia
Gesamtlänge	l_{38} [mm]	121	133	145	170	Overall length
Masse	m [kg]	1,1	1,3	1,5	1,9	Weight

DUM 6-Bx

- Mess-Systeme (X3):

A8/I8	EQI/ECI 13xx (Heidenhain)
AA	AD 34 (Hengstler)
IN	ERN 1185 (Heidenhain)
IR	SRS/SRM 50 (SICK-Stegmann)
IW	SKS/SKM 36 (SICK-Stegmann)
R9	Resolver Size 15 (2-oder 6-polig)

- Measuring systems (X3):

A8/I8	EQI/ECI 13xx (Heidenhain)
AA	AD 34 (Hengstler)
IN	ERN 1185 (Heidenhain)
IR	SRS/SRM 50 (SICK-Stegmann)
IW	SKS/SKM 36 (SICK-Stegmann)
R9	resolver size 15 (2- or 6-pole type)

X3= DUM 6-	ohne Bremse / without brake				mit Bremse / with brake			
	R9		A8/AA/I8/IN/IR/IW		R9		A8/AA/I8/IN/IR/IW	
	l ₃₈	r	l ₃₈	r	l ₃₈	r	l ₃₈	r
B 1	132	113	174	148	164	145	206	180
B 2	158	139	200	174	190	171	232	206
B 3	184	165	226	200	216	197	258	232

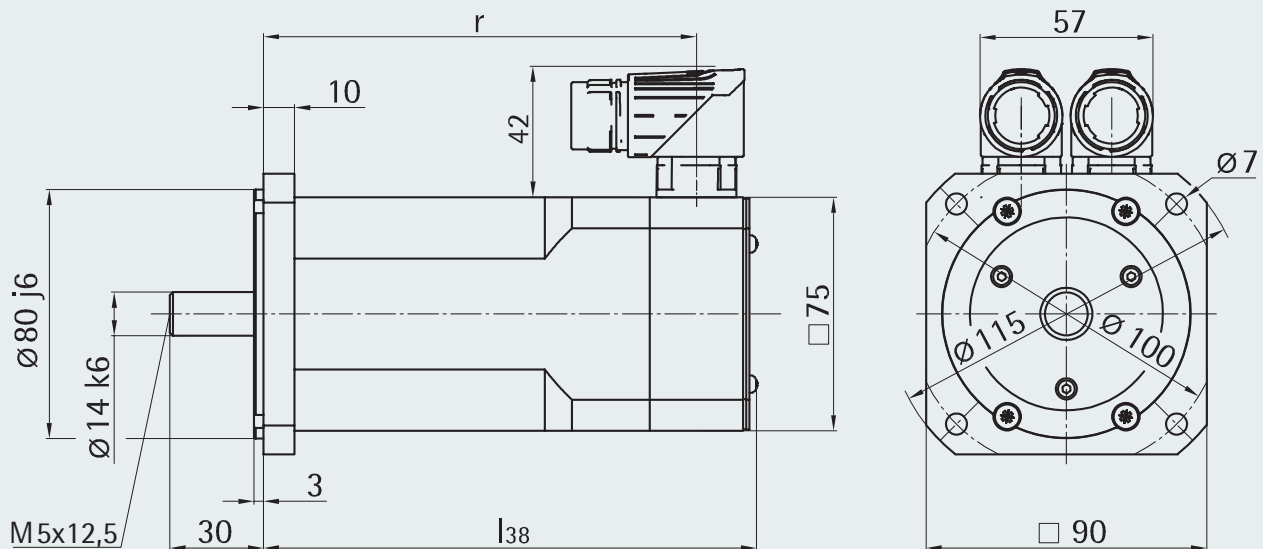

Selbstkühlung Self-cooling



DUM6-B2

Haltebremse		Holding brake		
Haftmoment	M_{Br}	Nm	4,5	Holding torque
Bemessungsspannung	U_{Br}	V	24	Rated voltage
Bemessungsstrom (20°C)	I_{Br}	A	0,58	Rated current
Masse	m	kg	0,28	Weight
Läuferträgheitsmoment	J_{Br}	kgcm ²	0,19	Rotor inertia

¹⁾ betriebswarm, Effektivwert, verkettet

²⁾ bei 20°C

³⁾ mit Resolver Size 15 (X3=R9), ohne Haltebremse

¹⁾ at operating temperature, r.m.s. value, phase to phase

²⁾ at 20°C

³⁾ with resolver size 15 (X3=R9), without holding brake

Kenngröße Einbaufenster, Baulänge Z2, Z3 Spannungs- u. Drehzahlvariante	DUM 6									Parameters Frame size, overall length Voltage and speed variant	
	- B1 -			- B2 -			- B3 -				
	2xx3	2xx4	2xx6	2xx3	2xx4	2xx6	2xx3	2xx4	2xx6		
Stillstandsrehmoment	M_{d0} [Nm]	0,92			1,8			2,6			Stall torque
Stillstandsstrom	I_{d0} [A]	1,0	1,2	1,5	1,6	2,0	2,5	2,3	2,7	3,9	Current at stall torque
Stillstandsrehmoment	M_{d10} [Nm]	0,94			1,84			2,65			Stall torque
Stillstandsstrom		I_{d10} [A]	1,0	1,2	1,5	1,6	2,0	2,6	2,4	2,8	4,1
Polzahl	2p	6									Number of poles
Bemessungsdaten											Nominal rating
Bemessungsrehmoment	M_{dN} [Nm]	0,9	0,87	0,76	1,83	1,75	1,5	2,6	2,5	2,3	Rated torque
Bemessungsstrom	I_{dN} [A]	1,0	1,2	1,3	1,7	2,1	2,3	2,6	2,9	3,6	Rated current
Bemessungsdrehzahl	n_N [min ⁻¹]	3000	4000	6000	3000	4000	6000	3000	4000	6000	Rated speed
Bemessungsleistung	P_{dN} [kW]	0,28	0,37	0,48	0,58	0,73	0,94	0,83	1,03	1,35	Rated power
Spannungskonstante ¹⁾	k_e [V/1000min ⁻¹]	54,1	44,4	35,4	64,0	51,0	39,6	61,5	52,6	36,4	Voltage constant ¹⁾
Wicklungswiderstand ²⁾	R_{u-v} [Ω]	37,2	24,6	15,7	17,7	11,1	6,9	9,3	7,6	3,4	Winding resistance ²⁾
Wicklungsinduktivität	L_{u-v} [mH]	66,0	44,4	28,3	41,4	26,3	15,9	25,1	18,4	8,8	Winding inductance
Maximalwerte											Max. values
max. Drehmoment	M_{max} [Nm]	2,7			5,4			7,8			Max. torque
max. Strom (Scheitelwert)	I_{max} [A]	3,6	4,5	5,5	6,1	7,7	9,9	9,2	10,8	15,5	Max. current (peak value)
max. Drehzahl	n_{max} [min ⁻¹]	9000									Max. perm. speed
mechan. Angaben ³⁾											Mechanical data ³⁾
Läuferträgheitsmoment	J_L [kgcm ²]	0,33			0,56			0,79			Inertia
Gesamtlänge	l_{38} [mm]	132			158			184			Overall length
Masse	m [kg]	2,3			3,0			3,7			Weight

DUM 6-Cx

- Mess-Systeme (X3):

A8/I8 EQI/ECI 13xx (Heidenhain)
 AA AD 34 (Hengstler)
 IR SRS/SRM 50 (SICK-Stegmann)
 IW SKS/SKM 36 (SICK-Stegmann)
 R9 Resolver Size 15 (2-oder 8-polig)

- Measuring systems (X3):

A8/I8 EQI/ECI 13xx (Heidenhain)
 AA AD 34 (Hengstler)
 IR SRS/SRM 50 (SICK-Stegmann)
 IW SKS/SKM 36 (SICK-Stegmann)
 R9 resolver size 15 (2- or 8-pole type)

DUM 6-	ohne Bremse / without brake				mit Bremse / with brake			
	R9		A8 / AA / I8 / IR / IW		R9		A8 / AA / I8 / IR / IW	
	l ₃₈	r	l ₃₈	r	l ₃₈	r	l ₃₈	r
C 1	178	158	220	193	214	194	256	229
C 2	206	186	248	221	242	222	284	257
C 3	234	214	276	249	270	250	312	285
C 4	262	242	304	277	298	278	340	313

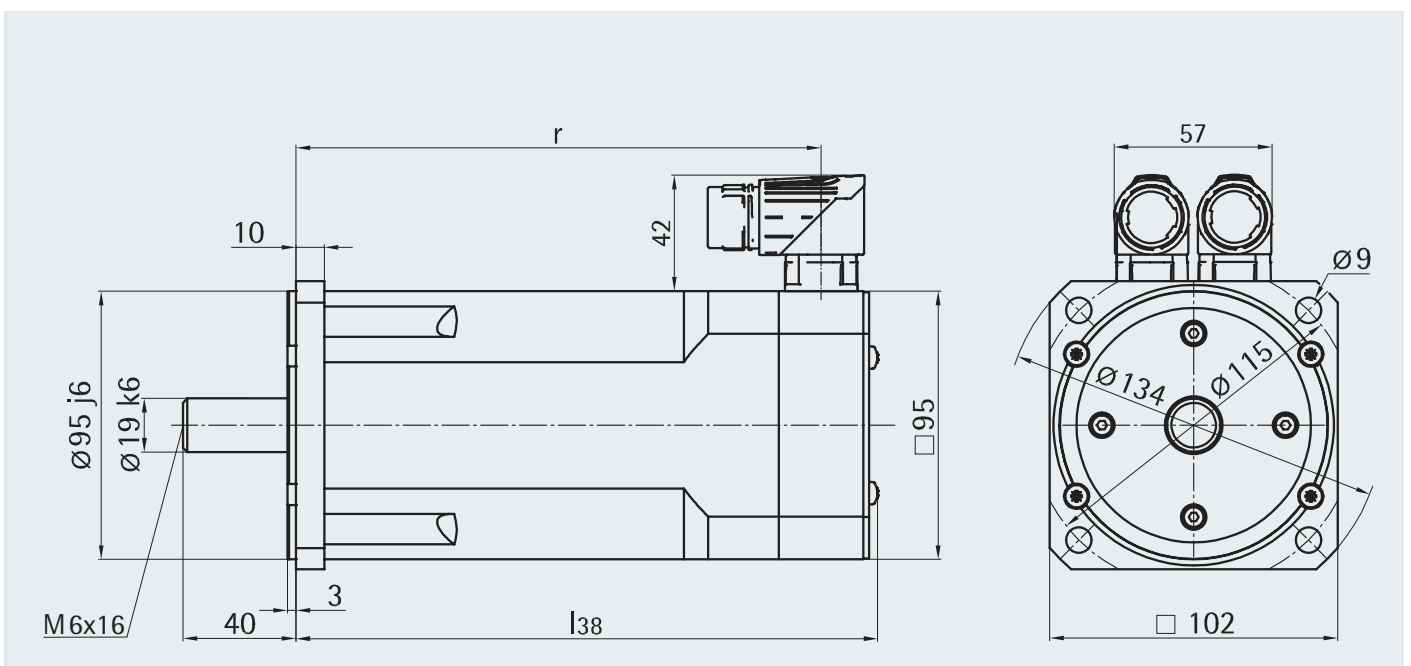

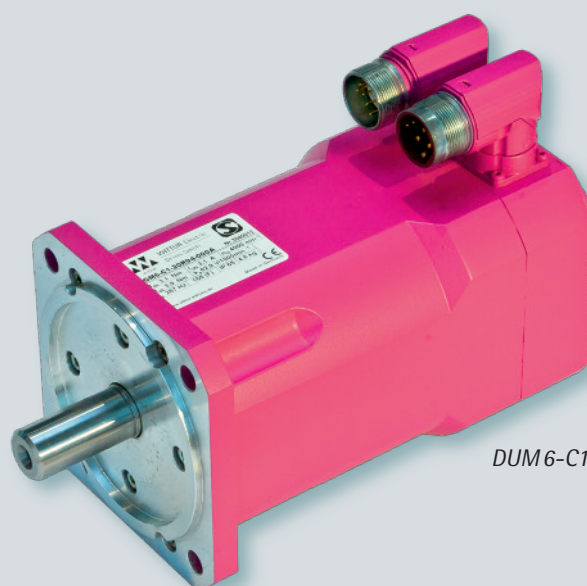

DUM6-C1

Haltebremse		Holding brake		
Haftmoment	M_{Br}	Nm	10	Holding torque
Bemessungsspannung	U_{Br}	V	24	Rated voltage
Bemessungsstrom (20°C)	I_{Br}	A	0,71	Rated current
Masse	m	kg	0,57	Weight
Läuferträgheitsmoment	J_{Br}	kgcm ²	1,01	Rotor inertia

¹⁾ betriebswarm, Effektivwert, verkettet

²⁾ bei 20°C

³⁾ mit Resolver Size 15 (X3=R9), ohne Haltebremse

¹⁾ at operating temperature, r.m.s. value, phase to phase

²⁾ at 20°C

³⁾ with resolver size 15 (X3=R9), without holding brake

Kenngröße	Einbaufenster, Baulänge Z2, Z3	Spannungs- u. Drehzahlvariante	DUM 6												Parameters Frame size, overall length Voltage and speed variant
			- C1 -			- C2 -			- C3 -			- C4 -			
			2xx2	2xx3	2xx4	2xx2	2xx3	2xx4	2xx2	2xx3	2xx4	2xx2	2xx3	2xx4	
Stillstandsrehmoment	M_{d0}	[Nm]	3,9			5,7			7,1			8,5			Stall torque
Stillstandsstrom	I_{d0}	[A]	2,5	3,1	3,9	3,8	5,0	6,1	5,7	7,0	8,8	5,5	8,5	10,7	Current at stall torque
Stillstandsrehmoment	M_{d10}	[Nm]	4,0			5,8			7,2			8,6			Stall torque
Stillstandsstrom	I_{d10}	[A]	2,5	3,1	3,9	3,8	5,1	6,2	4,5	5,5	6,9	4,3	6,7	8,4	Current at stall torque
Polzahl	2p		8												Number of poles
Bemessungsdaten			Nominal rating												
Bemessungsrehmoment	M_{dN}	[Nm]	3,8	3,5	3,1	5,5	4,8	4,2	6,9	6,4	5,7	8,3	7,6	6,8	Rated torque
Bemessungsstrom	I_{dN}	[A]	2,5	2,8	3,1	3,7	4,2	4,5	4,3	4,9	5,5	4,2	6,0	6,6	Rated current
Bemessungsdrehzahl	n_N	[min ⁻¹]	2000	3000	4000	2000	3000	4000	2000	3000	4000	2000	3000	4000	Rated speed
Bemessungsleistung	P_{dN}	[kW]	0,8	1,1	1,3	1,2	1,5	1,8	1,4	2,0	2,4	1,7	2,4	2,8	Rated power
Spannungskonstante ¹⁾	k_e	[V/1000min ⁻¹]	98,3	78,9	62,9	92,5	69,4	57,0	97,9	79,5	63,4	122	79,1	63,3	Voltage constant ¹⁾
Wicklungswiderstand ²⁾	R_{u-v}	[Ω]	11,6	7,4	4,7	6,1	3,6	2,4	4,4	2,9	1,8	5,3	2,2	1,4	Winding resistance ²⁾
Wicklungsinduktivität	L_{u-v}	[mH]	29,5	19,0	12,1	16,5	9,3	6,3	13,5	8,9	5,7	20,0	8,4	5,4	Winding inductance
Maximalwerte			Max. values												
max. Drehmoment	M_{max}	[Nm]	12			17,5			22			26			Max. torque
max. Strom (Scheitelwert)	I_{max}	[A]	8,4	10,5	13,2	12,6	16,8	20,4	16,2	20,0	25,1	15,3	23,8	29,6	Max. current (peak value)
max. Drehzahl	n_{max}	[min ⁻¹]	6000												Max. perm. speed
mechan. Angaben ³⁾			Mechanical data ³⁾												
Läuferträgheitsmoment	J_L	[kgcm ²]	2,7			3,7			4,7			6,0			Inertia
Gesamtlänge	l_{38}	[mm]	178			206			234			262			Overall length
Masse	m	[kg]	4,8			6,3			7,4			8,6			Weight

DUM 6-Dx

- Mess-Systeme (X3):
 - A8 / I8 EQI / ECI 13xx (Heidenhain)
 - AA AD 34 (Hengstler)
 - IR SRS / SRM 50 (SICK-Stegmann)
 - IW SKS / SKM 36 (SICK-Stegmann)
 - R9 Resolver Size 15 (2- oder 8-polig)

- Measuring systems (X3):
 - A8 / I8 EQI / ECI 13xx (Heidenhain)
 - AA AD 34 (Hengstler)
 - IR SRS / SRM 50 (SICK-Stegmann)
 - IW SKS / SKM 36 (SICK-Stegmann)
 - R9 resolver size 15 (2- or 8-pole type)

X3=	ohne Bremse / without brake				mit Bremse / with brake			
	R9		A8 / AA / I8 / IR / IW		R9		A8 / AA / I8 / IR / IW	
	l ₃₈	r	l ₃₈	r	l ₃₈	r	l ₃₈	r
D 1	203	182	245	217	237	216	279	251
D 2	233	212	275	247	267	246	309	281
D 3	263	242	305	277	297	276	339	311
D 4	293	272	335	307	327	306	369	341

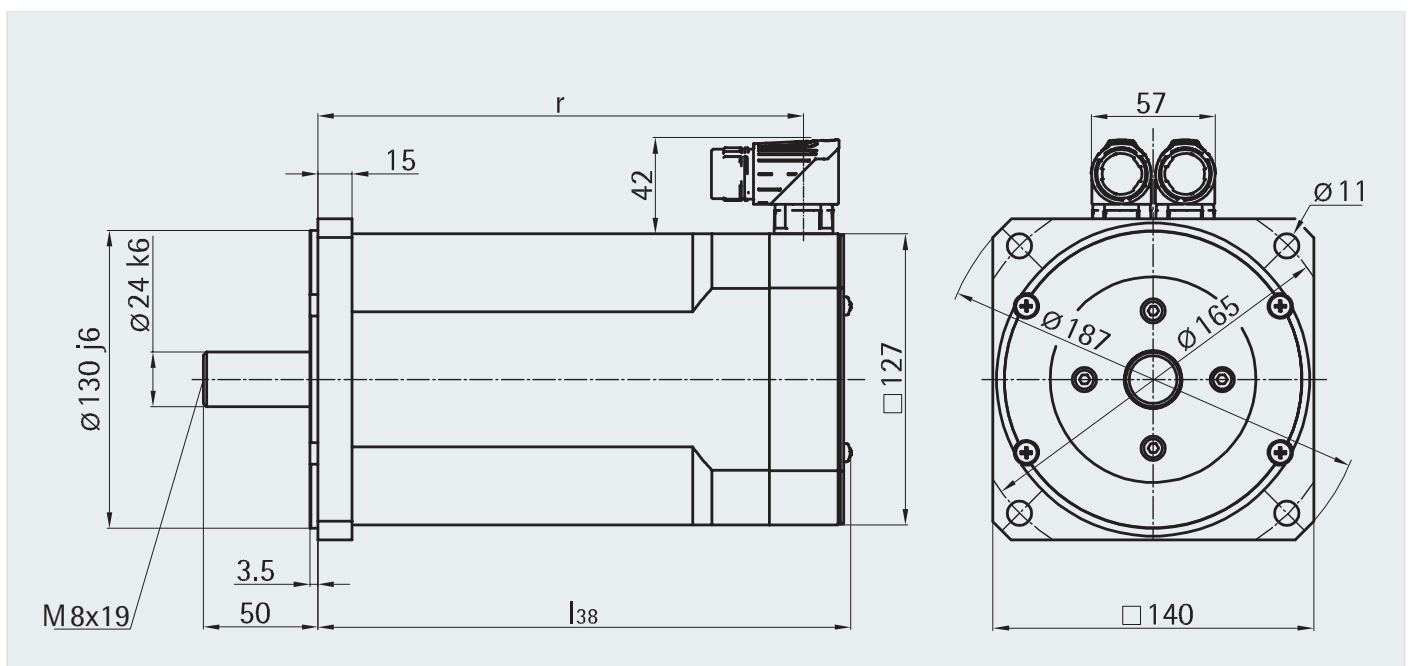

Selbstkühlung Self-cooling



DUM6-D1

Haltebremse		Holding brake		
Haftmoment	M_{Br}	Nm	22	Holding torque
Bemessungsspannung	U_{Br}	V	24	Rated voltage
Bemessungsstrom (20°C)	I_{Br}	A	0,83	Rated current
Masse	m	kg	1,15	Weight
Läuferträgheitsmoment	J_{Br}	kgcm ²	2,76	Rotor inertia

¹⁾ betriebswarm, Effektivwert, verkettet

²⁾ bei 20°C

³⁾ mit Resolver Size 15 (X3=R9), ohne Haltebremse

¹⁾ at operating temperature, r.m.s. value, phase to phase

²⁾ at 20°C

³⁾ with resolver size 15 (X3=R9), without holding brake

Kenngröße Einbaufenster, Baulänge Z2, Z3 Spannungs- u. Drehzahlvariante	DUM 6												Parameters Frame size, overall length Voltage and speed variant		
	- D1 -			- D2 -			- D3 -			- D4 -					
	2xx1	2xx2	2xx3	2xx1	2xx2	2xx3	2xx1	2xx2	2xx3	2xx1	2xx2	2xx3			
Stillstandsrehmoment	M_{d0}	[Nm]	8,2			11,6			15,3			18,4			Stall torque
Stillstandsstrom	I_{d0}	[A]	3,6	4,6	6,0	5,6	6,9	8,9	6,8	8,8	11,2	8,2	10,4	14,0	Current at stall torque
Stillstandsrehmoment	M_{d10}	[Nm]	8,3			11,8			15,6			18,8			Stall torque
Stillstandsstrom	I_{d10}	[A]	3,3	4,2	5,5	5,1	6,2	8,1	6,1	7,9	10,2	7,4	9,5	12,7	Current at stall torque
Polzahl	2p		8												Number of poles
Bemessungsdaten													Nominal rating		
Bemessungsrehmoment	M_{dN}	[Nm]	8,0	7,6	6,8	11,5	11,0	9,5	15,0	14,0	11,9	18,0	16,9	13,7	Rated torque
Bemessungsstrom	I_{dN}	[A]	3,3	4,0	4,6	5,1	6,0	6,7	6,1	7,3	8,0	7,4	8,8	9,6	Rated current
Bemessungsdrehzahl	n_N	[min ⁻¹]	1500	2000	3000	1500	2000	3000	1500	2000	3000	1500	2000	3000	Rated speed
Bemessungsleistung	P_{dN}	[kW]	1,3	1,6	2,1	1,8	2,3	3,0	2,4	2,9	3,8	2,8	3,5	4,3	Rated power
Spannungskonstante ¹⁾	k_e	[V/1000min ⁻¹]	150	118	90,3	138	112	86,9	151	117	91,0	150	118	87,9	Voltage constant ¹⁾
Wicklungswiderstand ²⁾	R_{u-v}	[Ω]	8,0	4,9	3,0	4,0	2,6	1,6	3,2	2,0	1,2	2,4	1,5	0,9	Winding resistance ²⁾
Wicklungsinduktivität	L_{u-v}	[mH]	35,0	21,5	12,7	19,0	12,6	7,5	15,3	9,2	5,6	9,4	5,8	3,2	Winding inductance
Maximalwerte													Max. values		
max. Drehmoment	M_{max}	[Nm]	25			36			47			57			Max. torque
max. Strom (Scheitelwert)	I_{max}	[A]	12,1	15,5	20,1	19,0	23,3	30,1	22,7	29,4	37,7	27,2	35,3	47,4	Max. current (peak value)
max. Drehzahl	n_{max}	[min ⁻¹]	4500												Max. perm. speed
mechan. Angaben ³⁾													Mechanical data ³⁾		
Läuferträgheitsmoment	J_L	[kgcm ²]	7,9			11,2			14,4			19,5			Inertia
Gesamtlänge	l_{38}	[mm]	203			233			263			293			Overall length
Masse	m	[kg]	10,0			11,9			14,0			18,0			Weight

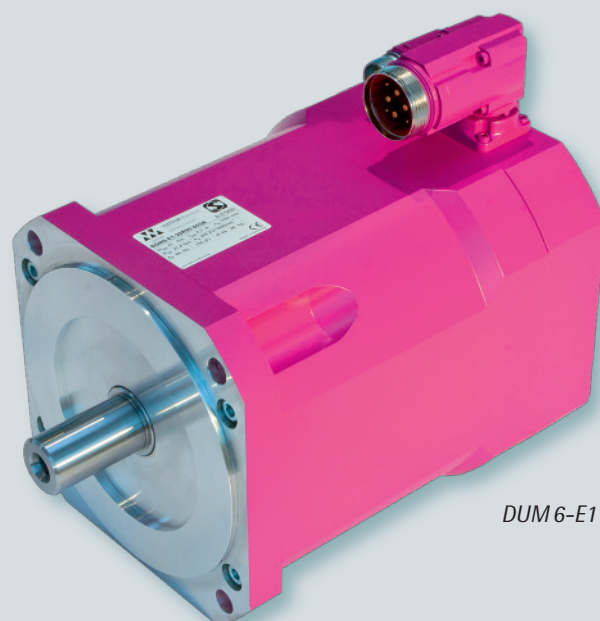

DUM6-E1

Haltebremse		Holding brake		
Haftmoment	M_{Br}	Nm	70	Holding torque
Bemessungsspannung	U_{Br}	V	24	Rated voltage
Bemessungsstrom (20°C)	I_{Br}	A	1,5	Rated current
Masse	m	kg	3,4	Weight
Läuferträgheitsmoment	J_{Br}	kgcm ²	20,1	Rotor inertia

¹⁾ betriebswarm, Effektivwert, verkettet

²⁾ bei 20°C

³⁾ mit Resolver Size 15 (X3=R9), ohne Haltebremse

¹⁾ at operating temperature, r.m.s. value, phase to phase

²⁾ at 20°C

³⁾ with resolver size 15 (X3=R9), without holding brake

Kenngröße Einbaufenster, Baulänge Z2, Z3 Spannungs- u. Drehzahlvariante	DUM 6									Parameters Frame size, overall length Voltage and speed variant	
	- E1 -			- E2 -			- E3 -				
	2xx0	2xx2	2xx3	2xx0	2xx2	2xx3	2xx0	2xx2	2xx3		
Stillstandsrehmoment	M_{d0} [Nm]	23,5			35			48			Stall torque
Stillstandsstrom	I_{d0} [A]	7,6	12,7	16,9	10,9	19,3	24,8	16,1	27,7	38,2	Current at stall torque
Stillstandsrehmoment	M_{d10} [Nm]	23,7			35,5			48,5			Stall torque
Stillstandsstrom		I_{d10} [A]	7,0	11,7	15,5	10,0	17,7	22,8	14,8	25,4	35,0
Polzahl	2p	8									Number of poles
Bemessungsdaten											Nominal rating
Bemessungsrehmoment	M_{dN} [Nm]	23	19	14	34	28	19	47	40	27	Rated torque
Bemessungsstrom	I_{dN} [A]	6,9	9,7	9,4	9,8	14,2	12,4	14,5	20,8	19,6	Rated current
Bemessungsdrehzahl	n_N [min ⁻¹]	1000	2000	3000	1000	2000	3000	1000	2000	3000	Rated speed
Bemessungsleistung	P_{dN} [kW]	2,4	4,0	4,4	3,6	5,8	6,0	4,9	8,3	8,4	Rated power
Spannungskonstante ¹⁾	k_e [V/1000min ⁻¹]	206	120,5	90,4	212,1	119,1	93	198,9	116,7	82,5	Voltage constant ¹⁾
Wicklungswiderstand ²⁾	R_{u-v} [Ω]	2,31	0,79	0,5	1,42	0,44	0,27	0,87	0,3	0,15	Winding resistance ²⁾
Wicklungsinduktivität	L_{u-v} [mH]	38,9	13,3	7,5	26,1	8,2	5,0	17,3	5,9	3,0	Winding inductance
Maximalwerte											Max. values
max. Drehmoment	M_{max} [Nm]	65			106			145			Max. torque
max. Strom (Scheitelwert)	I_{max} [A]	23,3	39,3	52,2	36,3	64,1	81,7	53,2	90,4	127	Max. current (peak value)
max. Drehzahl	n_{max} [min ⁻¹]	4000									Max. perm. speed
mechan. Angaben ³⁾											Mechanical data ³⁾
Läuferträgheitsmoment	J_L [kgcm ²]	57			79			102			Inertia
Gesamtlänge	l_{38} [mm]	266			294			322			Overall length
Masse	m [kg]	29			34			39			Weight

DUF 6-Cx

- Mess-Systeme (X3):
 - A8/I8 EQI/ECI 13xx (Heidenhain)
 - AA AD 34 (Hengstler)
 - IR SRS/SRM 50 (SICK-Stegmann)
 - IW SKS/SKM 36 (SICK-Stegmann)
 - R9 Resolver Size 15 (2-oder 8-polig)

- Measuring systems (X3):
 - A8/I8 EQI/ECI 13xx (Heidenhain)
 - AA AD 34 (Hengstler)
 - IR SRS/SRM 50 (SICK-Stegmann)
 - IW SKS/SKM 36 (SICK-Stegmann)
 - R9 resolver size 15 (2- or 8-pole type)

X3=	ohne Bremse / without brake				mit Bremse / with brake			
	R9		A8 / AA / I8 / IR / IW		R9		A8 / AA / I8 / IR / IW	
	l ₃₉	r	l ₃₉	r	l ₃₉	r	l ₃₉	r
DUF 6-								
C 1	259	158	301	193	295	194	337	229
C 2	287	186	329	221	323	222	365	257
C 3	315	214	357	249	351	250	393	285
C 4	343	242	385	277	379	278	421	313

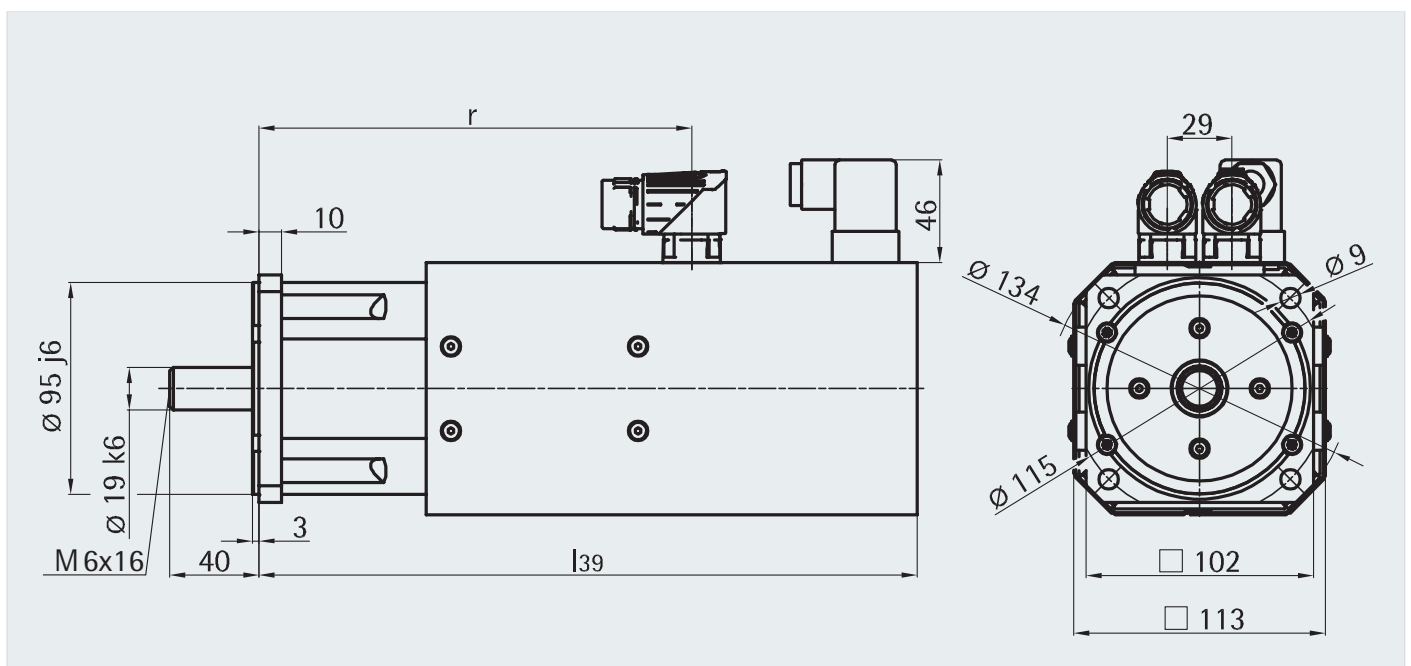

Fremdkühlung Forced-air cooling

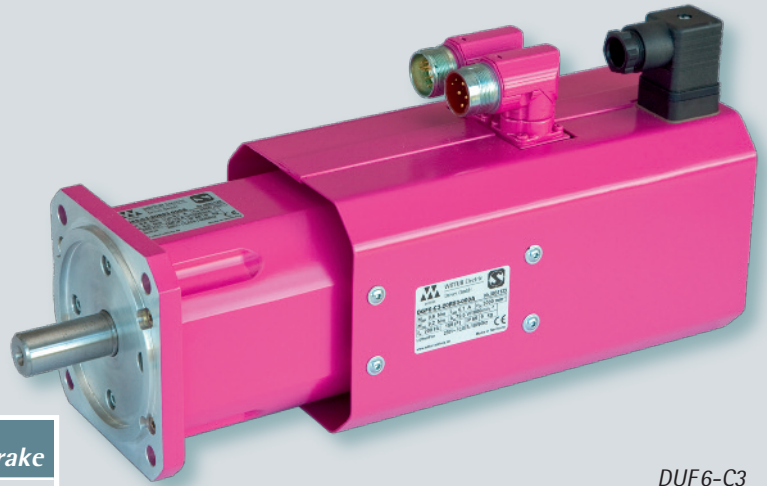

DUF6-C3

Haltebremse		Holding brake		
Haftmoment	M_{Br}	Nm	10	Holding torque
Bemessungsspannung	U_{Br}	V	24	Rated voltage
Bemessungsstrom (20°C)	I_{Br}	A	0,71	Rated current
Masse	m	kg	0,57	Weight
Läuferträgheitsmoment	J_{Br}	kgcm ²	1,01	Rotor inertia

¹⁾ betriebswarm, Effektivwert, verkettet

²⁾ bei 20°C

³⁾ mit Resolver Size 15 (X3=R9), ohne Haltebremse

¹⁾ at operating temperature, r.m.s. value, phase to phase

²⁾ at 20°C

³⁾ with resolver size 15 (X3=R9), without holding brake

Kenngröße	Einbaufenster, Baulänge Z2, Z3 Spannungs- u. Drehzahlvariante	DUF 6												Parameters Frame size, overall length Voltage and speed variant
		- C1 -			- C2 -			- C3 -			- C4 -			
		2xx2	2xx3	2xx4	2xx2	2xx3	2xx4	2xx2	2xx3	2xx4	2xx2	2xx3	2xx4	
Stillstandsrehmoment	M_{d0} [Nm]	5,0			7,4			9,2			11,1			Stall torque
Stillstandsstrom	I_{d0} [A]	3,2	4,0	5,0	4,9	6,5	7,9	7,4	9,1	11,4	7,1	11,0	13,7	Current at stall torque
Stillstandsrehmoment	M_{d10} [Nm]	5,2			7,7			9,5			11,4			Stall torque
Stillstandsstrom	I_{d10} [A]	3,3	4,1	5,2	5,0	6,7	8,2	5,9	7,3	9,1	5,6	8,7	10,9	Current at stall torque
Polzahl	2p	8												Number of poles
Bemessungsdaten													Nominal rating	
Bemessungsrehmoment	M_{dN} [Nm]	5,2	4,7	4,2	7,4	6,4	5,6	9,3	8,6	7,7	11,2	10,3	9,2	Rated torque
Bemessungsstrom	I_{dN} [A]	3,3	3,8	4,2	4,9	5,7	6,1	5,8	6,7	7,5	5,7	8,0	8,9	Rated current
Bemessungsdrehzahl	n_N [min ⁻¹]	2000	3000	4000	2000	3000	4000	2000	3000	4000	2000	3000	4000	Rated speed
Bemessungsleistung	P_{dN} [kW]	1,1	1,5	1,8	1,6	2,0	2,4	1,9	2,7	3,2	2,3	3,2	3,8	Rated power
Spannungskonstante ¹⁾	k_e [V/1000min ⁻¹]	98,3	78,9	62,9	92,5	69,4	57,0	97,9	79,5	63,4	122	79,1	63,3	Voltage constant ¹⁾
Wicklungswiderstand ²⁾	R_{u-v} [Ω]	11,6	7,4	4,7	6,1	3,6	2,4	4,4	2,9	1,8	5,3	2,2	1,4	Winding resistance ²⁾
Wicklungsinduktivität	L_{u-v} [mH]	29,5	19,0	12,1	16,5	9,3	6,3	13,5	8,9	5,7	20,0	8,4	5,4	Winding inductance
Maximalwerte													Max. values	
max. Drehmoment	M_{max} [Nm]	12			17,5			22			26			Max. torque
max. Strom (Scheitelwert)	I_{max} [A]	8,4	10,5	13,2	12,6	16,8	20,4	16,2	20,0	25,1	15,3	23,8	29,6	Max. current (peak value)
max. Drehzahl	n_{max} [min ⁻¹]	6000												Max. perm. speed
mechan. Angaben ³⁾													Mechanical data ³⁾	
Läuferträgheitsmoment	J_L [kgcm ²]	2,7			3,7			4,7			6,0			Inertia
Gesamtlänge	l_{39} [mm]	259			287			315			343			Overall length
Masse	m [kg]	6,3			7,8			9,0			10,4			Weight

DUF 6-Dx

- Mess-Systeme (X3):

A8/I8 EQI/ECI 13xx (Heidenhain)
 AA AD 34 (Hengstler)
 IR SRS/SRM 50 (SICK-Stegmann)
 IW SKS/SKM 36 (SICK-Stegmann)
 R9 Resolver Size 15 (2-oder 8-polig)

- Measuring systems (X3):

A8/I8 EQI/ECI 13xx (Heidenhain)
 AA AD 34 (Hengstler)
 IR SRS/SRM 50 (SICK-Stegmann)
 IW SKS/SKM 36 (SICK-Stegmann)
 R9 resolver size 15 (2- or 8-pole type)

DUF 6-	ohne Bremse / without brake				mit Bremse / with brake			
	R9		A8 / AA / I8 / IR / IW		R9		A8 / AA / I8 / IR / IW	
	l ₃₉	r	l ₃₉	r	l ₃₉	r	l ₃₉	r
D 1	285	182	327	217	319	216	361	251
D 2	315	212	357	247	349	246	391	281
D 3	345	242	387	277	379	276	421	311
D 4	375	272	417	307	409	306	451	341

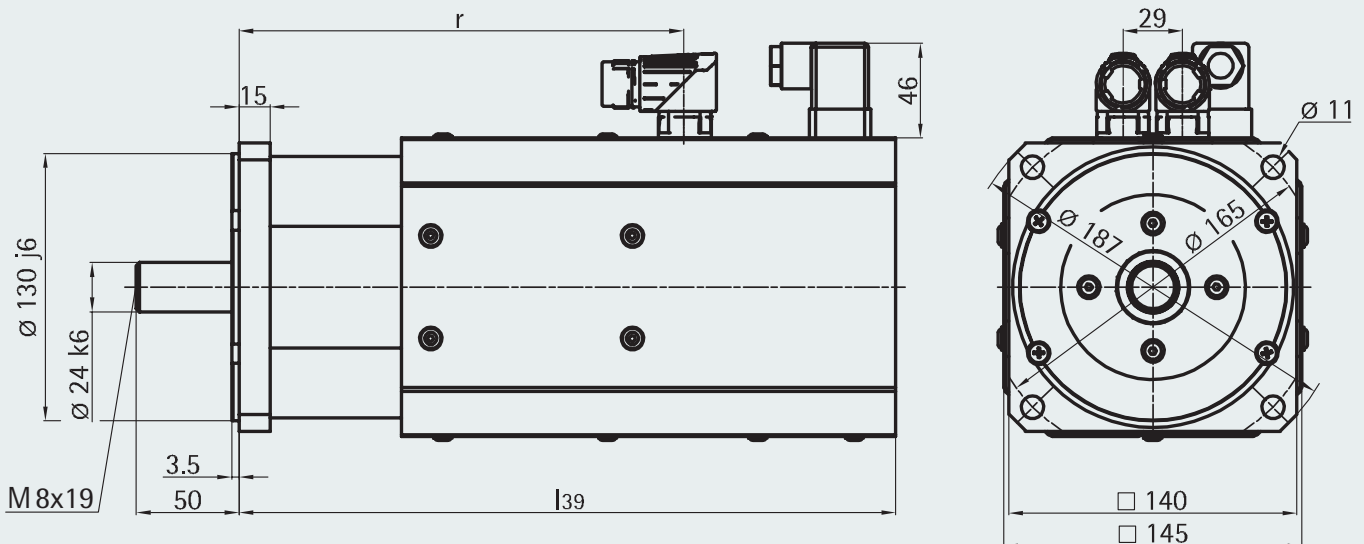

Fremdkühlung Forced-air cooling

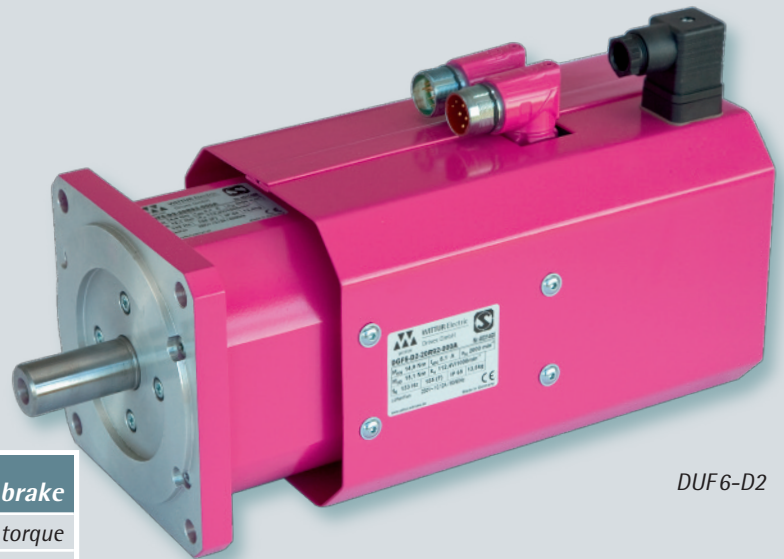

DUF6-D2

Haltebremse		Holding brake		
Haftmoment	M_{Br}	Nm	22	Holding torque
Bemessungsspannung	U_{Br}	V	24	Rated voltage
Bemessungsstrom (20°C)	I_{Br}	A	0,83	Rated current
Masse	m	kg	1,15	Weight
Läuferträgheitsmoment	J_{Br}	kgcm ²	2,76	Rotor inertia

¹⁾ betriebswarm, Effektivwert, verkettet

²⁾ bei 20°C

³⁾ mit Resolver Size 15 (X3=R9), ohne Haltebremse

¹⁾ at operating temperature, r.m.s. value, phase to phase

²⁾ at 20°C

³⁾ with resolver size 15 (X3=R9), without holding brake

Kenngröße	Einbaufenster, Baulänge Z2, Z3 Spannungs- u. Drehzahlvariante	DUF 6											Parameters Frame size, overall length Voltage and speed variant	
		- D1 -			- D2 -			- D3 -			- D4 -			
		2xx1	2xx2	2xx3	2xx1	2xx2	2xx3	2xx1	2xx2	2xx3	2xx1	2xx2		2xx3
Stillstandsrehmoment	M_{d0} [Nm]	10,6			15,1			19,9			23,9			Stall torque
Stillstandsstrom	I_{d0} [A]	4,7	6,0	7,9	7,3	9,0	11,6	8,8	11,4	14,6	10,7	13,6	18,2	Current at stall torque
Stillstandsrehmoment	M_{d10} [Nm]	11,0			15,6			20,6			24,8			Stall torque
Stillstandsstrom	I_{d10} [A]	4,4	5,6	7,2	6,7	8,2	10,6	8,1	10,5	13,4	9,8	12,5	16,7	Current at stall torque
Polzahl	2p	8											Number of poles	
Bemessungsdaten												Nominal rating		
Bemessungsrehmoment	M_{dN} [Nm]	10,8	10,3	9,1	15,6	14,9	12,8	20,2	18,9	16,1	24,3	22,8	18,5	Rated torque
Bemessungsstrom	I_{dN} [A]	4,4	5,4	6,2	6,9	8,1	9,1	8,2	9,9	10,9	9,9	11,9	12,9	Rated current
Bemessungsdrehzahl	n_N [min ⁻¹]	1500	2000	3000	1500	2000	3000	1500	2000	3000	1500	2000	3000	Rated speed
Bemessungsleistung	P_{dN} [kW]	1,7	2,2	2,9	2,4	3,1	4,0	3,2	4,0	5,1	3,8	4,8	5,8	Rated power
Spannungskonstante ¹⁾	k_e [V/1000min ⁻¹]	150	118	90,3	138	112	86,9	151	117	91,0	150	118	87,9	Voltage constant ¹⁾
Wicklungswiderstand ²⁾	R_{u-v} [Ω]	8,0	4,9	3,0	4,0	2,6	1,6	3,2	2,0	1,2	2,4	1,5	0,9	Winding resistance ²⁾
Wicklungsinduktivität	L_{u-v} [mH]	35,0	21,5	12,7	19,0	12,6	7,5	15,3	9,2	5,6	9,4	5,8	3,2	Winding inductance
Maximalwerte												Max. values		
max. Drehmoment	M_{max} [Nm]	25			36			47			57			Max. torque
max. Strom (Scheitelwert)	I_{max} [A]	12,1	15,5	20,1	19,0	23,3	30,1	22,7	29,4	37,7	27,2	35,3	47,4	Max. current (peak value)
max. Drehzahl	n_{max} [min ⁻¹]	4500											Max. perm. speed	
mechan. Angaben ³⁾												Mechanical data ³⁾		
Läuferträgheitsmoment	J_L [kgcm ²]	7,9			11,2			14,4			19,5			Inertia
Gesamtlänge	l_{39} [mm]	285			315			345			375			Overall length
Masse	m [kg]	11,9			13,8			16,2			20,4			Weight

DUF 6-Ex

- Mess-Systeme (X3):

A8/I8 EQI/ECI 13xx (Heidenhain)
 AA AD 34 (Hengstler)
 IR SRS/SRM 50 (SICK-Stegmann)
 IW SKS/SKM 36 (SICK-Stegmann)
 R9 Resolver Size 15 (2-oder 8-polig)

- Measuring systems (X3):

A8/I8 EQI/ECI 13xx (Heidenhain)
 AA AD 34 (Hengstler)
 IR SRS/SRM 50 (SICK-Stegmann)
 IW SKS/SKM 36 (SICK-Stegmann)
 R9 resolver size 15 (2- or 8-pole type)

X3=	ohne Bremse / without brake				mit Bremse / with brake			
	R9		A8 / AA / I8 / IR / IW		R9		A8 / AA / I8 / IR / IW	
	l ₃₉	r	l ₃₉	r	l ₃₉	r	l ₃₉	r
DUF 6-								
E 1	380	237	407	264	414	271	441	298
E 2	408	265	435	292	442	299	469	326
E 3	436	293	463	320	470	327	497	354

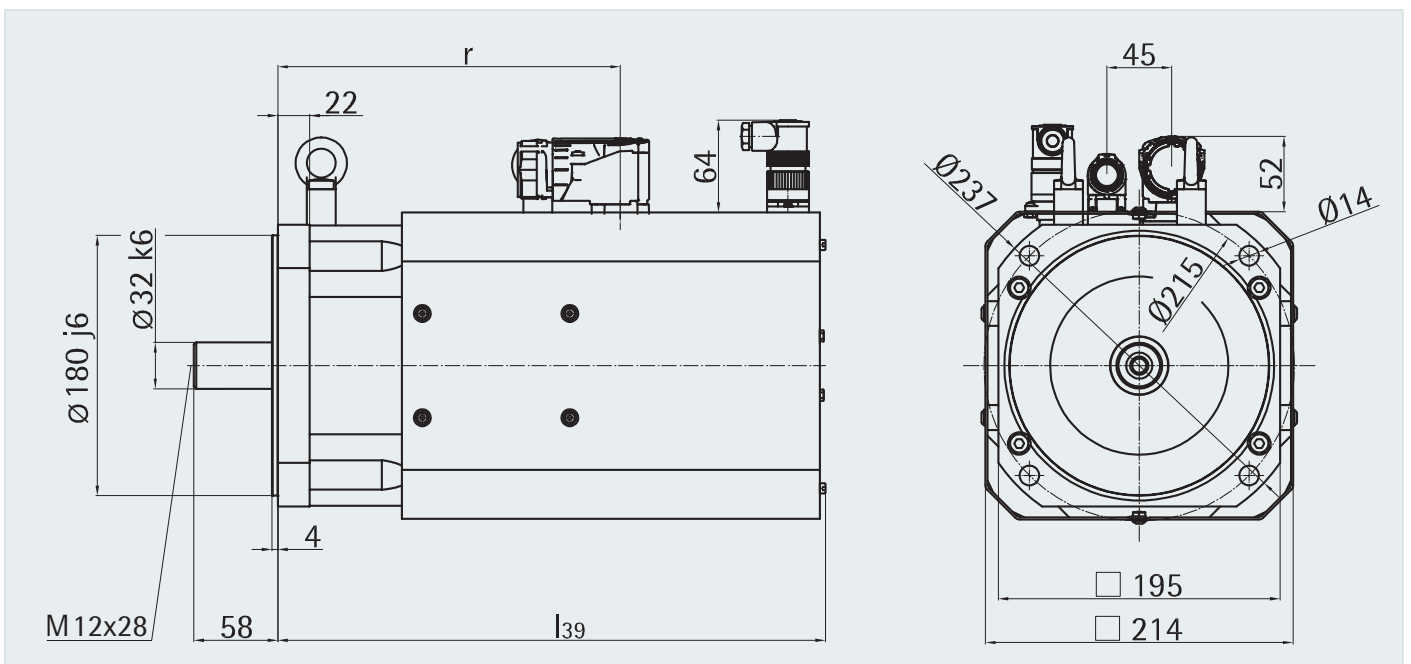

Fremdkühlung Forced-air cooling

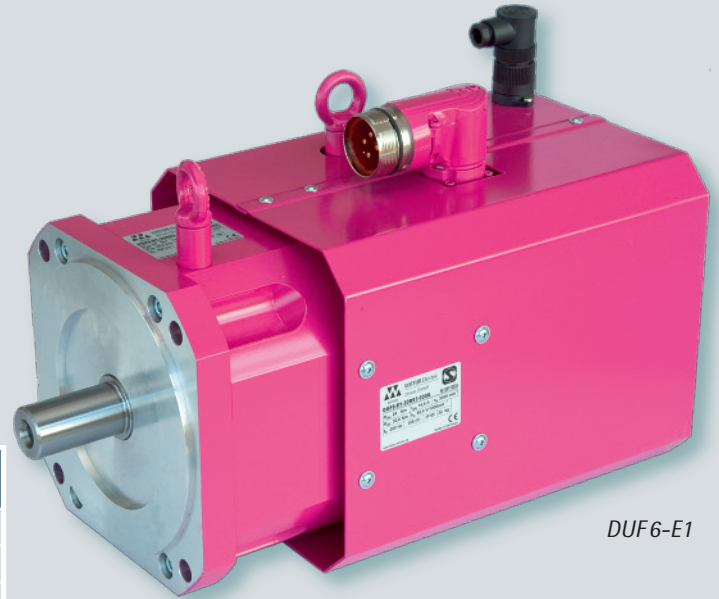

DUF6-E1

Haltebremse		Holding brake		
Haftmoment	M_{Br}	Nm	70	Holding torque
Bemessungsspannung	U_{Br}	V	24	Rated voltage
Bemessungsstrom (20°C)	I_{Br}	A	1,5	Rated current
Masse	m	kg	3,4	Weight
Läuferträgheitsmoment	J_{Br}	kgcm ²	20,1	Rotor inertia

¹⁾ betriebswarm, Effektivwert, verkettet

²⁾ bei 20°C

³⁾ mit Resolver Size 15 (X3=R9), ohne Haltebremse

¹⁾ at operating temperature, r.m.s. value, phase to phase

²⁾ at 20°C

³⁾ with resolver size 15 (X3=R9), without holding brake

Kenngröße Einbaufenster, Baulänge Z2, Z3 Spannungs- u. Drehzahlvariante	DUF 6										Parameters Frame size, overall length Voltage and speed variant		
	- E1 -			- E2 -			- E3 -						
	2x0	2x2	2x3	2x0	2x2	2x3	2x0	2x2	2x3				
Stillstandsrehmoment	M_{d0}	[Nm]	30,6			45,5			62,5			Stall torque	
Stillstandsstrom	I_{d0}	[A]	9,9	17,1	22,8	14,4	25,5	32,5	21,4	36,9	51,6	Current at stall torque	
Stillstandsrehmoment	M_{d10}	[Nm]	30,8			45,8			63			Stall torque	
Stillstandsstrom	I_{d10}	[A]	9,1	15,1	20,2	13,0	23,0	29,6	19,2	33,0	45,6	Current at stall torque	
Polzahl		2p	8										Number of poles
Bemessungsdaten											Nominal rating		
Bemessungsrehmoment	M_{dN}	[Nm]	30	28	24	45	40	34	62	57	48	Rated torque	
Bemessungsstrom	I_{dN}	[A]	9,3	14,4	16,6	13,3	21,0	22,3	19,9	30,8	36,2	Rated current	
Bemessungsdrehzahl	n_N	[min ⁻¹]	1000	2000	3000	1000	2000	3000	1000	2000	3000	Rated speed	
Bemessungsleistung	P_{dN}	[kW]	3,1	5,8	7,6	4,7	8,4	10,6	6,5	11,9	15,2	Rated power	
Spannungskonstante ¹⁾	k_e	[V/1000min ⁻¹]	206	120,5	90,4	212,1	119,1	93	198,9	116,7	82,5	Voltage constant ¹⁾	
Wicklungswiderstand ²⁾	R_{u-v}	[Ω]	2,31	0,79	0,5	1,42	0,44	0,27	0,87	0,3	0,15	Winding resistance ²⁾	
Wicklungsinduktivität	L_{u-v}	[mH]	38,9	13,3	7,5	26,1	8,2	5,0	17,3	5,9	3,0	Winding inductance	
Maximalwerte											Max. values		
max. Drehmoment	M_{max}	[Nm]	65			106			145			Max. torque	
max. Strom (Scheitelwert)	I_{max}	[A]	23,3	39,3	52,2	36,3	64,1	81,7	53,2	90,4	127	Max. current (peak value)	
max. Drehzahl	n_{max}	[min ⁻¹]	4000										Max. perm. speed
mechan. Angaben ³⁾											Mechanical data ³⁾		
Läuferträgheitsmoment	J_L	[kgcm ²]	57			79			102			Inertia	
Gesamtlänge	l_{39}	[mm]	380			414			448			Overall length	
Masse	m	[kg]	32			37			42			Weight	

Unsere Produktpalette

- Drehstrom Hauptantriebsmotoren
DSM • 3,7 bis 700 kW
- Torquemotoren, synchron
TMS 0 • 110 bis 2400 Nm
- Drehstrom Servomotoren, synchron
DUM 6 • 0,4 bis 63 Nm
DUM 4 • 0,3 bis 218 Nm
- Getriebelose Aufzugsmaschinen
WSG/WLG • bis 5.000 Nm
- Konfektionierung von Motoranschluss- und Systemkabeln
- Sondermotoren nach Kundenforderungen

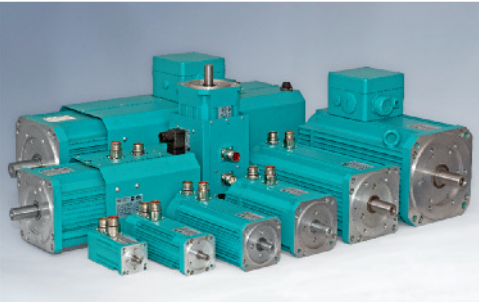
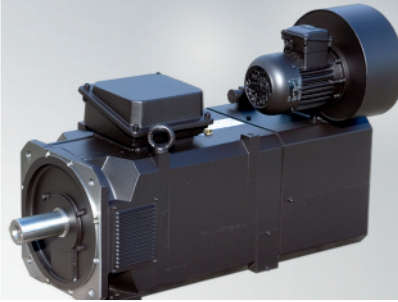
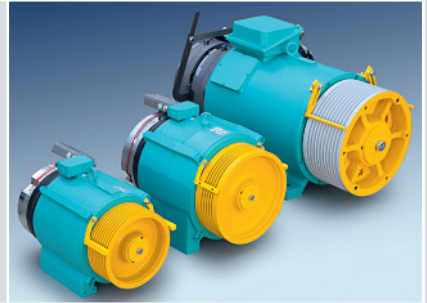

Our product range

- *Three-phase main drive motors*
DSM • 3.7 to 700 kW
- *Torque motors, synchronous*
TMS 0 • 110 to 2400 Nm
- *Three-phase servomotors, synchronous*
DUM 6 • 0.4 to 63 Nm
DUM 4 • 0.3 to 280 Nm
- *Gearless lift machines*
WSG/WLG • up to 5,000 Nm
- *Finishing of motor connection and system cable sets*
- *Custom-made special motors*

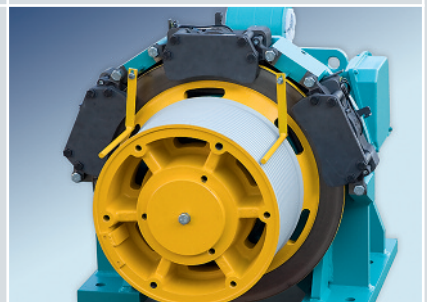
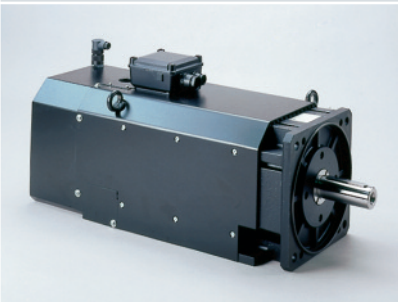

WITTUR Electric
Drives GmbH



Offenburger Str. 3
D-01189 Dresden

Phone +49 (0) 351 40 44-0
Fax +49 (0) 351 40 44-1 11

www.wittur-edrives.de
info.wed@wittur.com

Die Informationen in diesem Prospekt verstehen sich nur als Richtlinien und sind keine verbindlichen Daten. Die WITTUR Electric Drives GmbH verfügt über eine laufende Produktentwicklung und behält sich das Recht vor, Spezifikationen ohne Benachrichtigung zu ändern.

The data contained in this brochure are intended as guide lines and are not binding. WITTUR Electric Drives GmbH is constantly developing and improving its products and reserves the right to change specifications without notification.