

SRUS

DUM 6 DUF 6

Servomotors

Rated continuous torques
from 0.4 Nm to 63 Nm

Operating Manual



WITTUR Electric
Drives GmbH



These operating instructions are applicable to servomotors

DUM 6-

DUF 6-

Edition: 06 August 2014 V 18

WITTUR Electric Drives GmbH reserves the right to correct or change the contents of this information and product details without prior notice. No liability can be accepted for damage, injuries or outlay arising therefrom. We cannot warrant the correctness and completeness of the details.



WITTUR Electric

Drives GmbH

Offenburger Str. 3
D-01189 Dresden
Germany

Tel. +49(0)3 51-40 44-0

Fax +49(0)3 51-40 44-1 11

info@wittur-edrives.de

www.wittur-edrives.de



Contents

Safety instructions	4
EC Declaration of Conformity	5
Overview	6
Basic features	7
Speed-torque characteristic	8
Standards, codes and regulations	8
Construction, definitions	9
Drive end	9
Direction of rotation	9
Nameplate	9
Symbols	9
Installation and operation	10
Degree of protection	10
Cooling, altitude, ambient conditions	10
Shaft ends	11
Holding brake	11
Winding, insulation system	12
Separately driven fan	12
Conductor size	12
Speed and shaft position measuring system / resolver	12
Monitoring the winding temperature	13
Transport and packaging	14
Storage	15
Maintenance	15
Safety instructions	15
Maintenance intervals	15
Permissible axial and radial forces	16
Axial forces	16
Radial forces	17
Connection system DUM/F 6-A...D	18
Accessories	18
Connection system DUM/F 6-E	19
Accessories	19
Type code	20
Technical data DUM 6-A...	22
Technical data DUM 6-B...	24
Technical data DUM 6-C...	26
Technical data DUM 6-D...	28
Technical data DUM 6-E...	30
Technical data DUF 6-C...	32
Technical data DUF 6-D...	34
Technical data DUF 6-E...	36

Safety instructions

The motors of the series DUM/F 6 are designed for use in commercial plants. They comply with the harmonised standards of the series VDE 0530/EN 60034. They are not to be operated in hazardous areas unless expressly permitted (note additional reference).

The local conditions on site shall comply with the nameplate data. During operation (even at zero speed), the motors possess dangerous live and moving parts and may have hot surfaces. Only qualified and competent specialist personnel are allowed to handle, connect, commission and maintain the motors. (Observe VDE 0105; IEC 364). Improper conduct may result in serious injury to persons and property.

In this manual, the following pictograms are used to mark warnings and important notes.



means that death or serious injury to persons or property will occur unless the appropriate precautions are taken.



means that death or serious injury to persons or property may occur unless the appropriate precautions are taken.



means that slight injury or damage to persons or property may occur unless the appropriate precautions are taken.

Only qualified personnel are allowed to perform any planning, installation or maintenance work.

The personnel must be trained for the job and must be familiar with the installation, assembly, commissioning and operation of the product.

The instructions given in this manual or any other instructions supplied must always be observed.



- Remove power to the machine before starting any work on the motors.
- Check the proper functioning of the brake (if provided) after installing the motor.
- Repairs may only be carried out by the manufacturer or an authorised repair agency. Unauthorised opening and tampering may lead to bodily injury and property damage and may entail the loss of warranty rights.
- Before commissioning motors with a shaft key, secure the key to ensure that it cannot be thrown out if this is not already prevented by driving elements such as a belt pulley, coupling, etc.



- The motors are not designed for direct connection to the three-phase system but are to be operated via an electronic power converter. Direct connection to the system may destroy the motor.
- Surface temperatures of more than 100°C may occur on the motors. Therefore, no temperature-sensitive parts must be allowed to come into contact or be attached to them. Protection against accidental contact should be provided, if required.
- The optional holding brake is only designed for a limited number of emergency brakings. Never use it as a working brake.
- On motors with plug connector and built-in brake, it is the user's responsibility to install the varistor provided to control the brake.
- Connect the winding temperature sensor and evaluate its signal by means of a suitable circuitry. The temperature sensor protects the motor from thermal overload if the temperature change is slow. It does not, however, provide an allround protection. Therefore, additional measures such as monitoring I²t by the converter electronic system are required to protect the motor from fastrising thermal overload.
- Dangerous voltages are applied at the terminals of synchronous motors when the rotor is turning.

WITTUR Electric
Drives GmbH

EG-Konformitätserklärung EC Declaration of Conformity

im Sinne der EG-Richtlinie Niederspannung (2006/95/EG)
as defined by the EC Low Voltage Directive (2006/95/EC)

Der Hersteller
The manufacturer

WITTUR Electric Drives GmbH
Offenburger Straße 3
D-01189 Dresden

erklärt hiermit, dass die folgenden Produkte
certifies that the following products

Produktbezeichnung:
Product designation:

Asynchronmotoren Asynchronous motors	DS□ 1, DS□ 3, SDM, WLG, 2S□ 3, 6S□ 3
Synchronmotoren Synchronous motors	DS□ 2, DS□ 4, DG□ 4, DU□ 4, DG□ 6, DU□ 6, SDM, TMS 0, WSG
Sondermotoren Custom-made motors	EPX, 6PX, 4HX, APX, MMX, NPX, OPX, QPX

den Bestimmungen der EG-Richtlinie 2006/95/EG entsprechen.
are in conformity with the specification of the EC Directive 2006/95/EC.

Erklärung zur EMV-Richtlinie (2004/108/EG)

Bei Netzbetrieb an sinusförmiger Wechselspannung erfüllen die Motoren die Anforderungen der EG-Richtlinie „Elektromagnetische Verträglichkeit“ 2004/108/EG unter Berücksichtigung der Normen EN 61000-6-1...4.

Statement relating to EMC Directive (2004/108/EC)

When connected to a sinus-shaped a.c. voltage system, the motors conform to the requirements of the EC Directive "Electromagnetic compatibility" 2004/108/EC, including those specified in standards EN 61000-6-1...4.

Folgende Normen sind angewandt:

The following standards are in use:

- EN / IEC 60 204-1:** Sicherheit von Maschinen; Elektrische Ausrüstung von Maschinen;
Teil 1: Allg. Anforderungen
Safety of machinery - Electrical equipment of machines. Part 1: General requirements
- EN / IEC 60 034:** Drehende elektrische Maschinen
Rotating electrical machines
- EN ISO 12 100-1:** Sicherheit von Maschinen - Allgemeine Gestaltungsleitsätze,
EN ISO 12 100-2 Risikobeurteilung und Risikominimierung
Safety of machinery - General principles for design, risk assessment and risk reduction

Dresden, 2013-12-09

(Ort, Datum)
(Place, date)

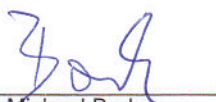
Dr. Michael Bork
Geschäftsführer
General Manager

Steffen Mann
Leiter Entwicklung/Konstruktion
Head of Development/Construction

Overview

Motor type		Stall torque	Rated torque at					
		10 min ⁻¹	1.000 min ⁻¹	1.500 min ⁻¹	2.000 min ⁻¹	3.000 min ⁻¹	4.000 min ⁻¹	6.000 min ⁻¹
		M _{d10} [Nm]	M _{dN} [Nm]	M _{dN} [Nm]	M _{dN} [Nm]	M _{dN} [Nm]	M _{dN} [Nm]	M _{dN} [Nm]
self-cooling	DUM6-A1	0,48						0,43
	DUM6-A2	0,68						0,62
	DUM6-A3	0,89						0,80
	DUM6-A4	1,17						1,05
	DUM6-B1	0,94				0,9	0,87	0,76
	DUM6-B2	1,84				1,83	1,75	1,5
	DUM6-B3	2,65				2,6	2,5	2,3
	DUM6-C1	4,0			3,8	3,5	3,1	
	DUM6-C2	5,8			5,5	4,8	4,2	
	DUM6-C3	7,2			6,9	6,4	5,7	
	DUM6-C4	8,6			8,3	7,6	6,8	
	DUM6-D1	8,3		8,0	7,6	6,8		
	DUM6-D2	11,8		11,5	11,0	9,5		
	DUM6-D3	15,6		15,0	14,0	11,9		
	DUM6-D4	18,8		18,0	16,9	13,7		
	DUM6-E1	23,7	23,0		19,0	14,0		
	DUM6-E2	35,5	34,4		28,0	19,0		
	DUM6-E3	48,5	47,0		40,0	27,0		
enforced-cooling	DUF6-C1	5,2			5,2	4,7	4,2	
	DUF6-C2	7,7			7,4	6,4	5,6	
	DUF6-C3	9,5			9,3	8,6	7,7	
	DUF6-C4	11,4			11,2	10,3	9,2	
	DUF6-D1	11,0		10,8	10,3	9,1		
	DUF6-D2	15,6		15,6	14,9	12,8		
	DUF6-D3	20,6		20,2	18,9	16,1		
	DUF6-D4	24,8		24,3	22,8	18,5		
	DUF6-E1	30,8	30		28	24		
	DUF6-E2	45,8	45		40	34		
	DUF6-E3	63	62		57	48		

Basic features

	Standard	Options
Construction type	IMB5 (IMV1, IMV3)	
Degree of protection	IP 65	
Shaft exit	IP 64	IP 65
Motor type	permanent-field synchronous servomotor	
Magnet material	neodymium-iron-boron	
Rated data	for duty S1 (continuous operation)	
Vibrational severity	B	
Flange accuracy	N	R
Thermal class	155 (F); wire insulation class 180 (H)	
Winding protection	thermistor (PTC) 150°C (with reinforced insulation to EN 50178)	KTY 84; KTY 83; miniature thermal-delay switch
Connection to system	connector (rotatable, speedTEC-compatible)	
Measuring system connection	connector (rotatable, speedTEC-compatible)	
Measuring system	resolver	absolute sine-cosine encoder
Cooling	self-cooling	enforced cooling
Brake	-	permanent-field holdig brake
Paint finish	RAL 9005 (dull black)	special paints
Bearings	radial deep-groove ball bearing, life-lubricated (locating bearing at D-end)	
Shaft end	plain shaft end	key (to DIN 6885) balanced with half-key
Ambient temperature range	from -15°C to +40°C	
Max. rel. humidity	90 % at 20°C (no moisture condensation)	
UL-file number	E 234 973	

Speed-torque characteristic

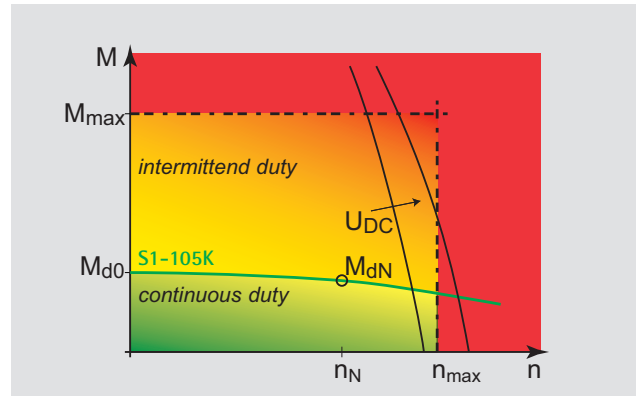

Definitions

M_{d0}	Stall torque	Thermal limiting torque of the motor at standstill ($n=0 \text{ min}^{-1}$). This torque can be delivered for any length of time (S1).
M_{d10}	Stall torque	Thermal limiting torque of the motor at $n > 10 \text{ min}^{-1}$. This torque can be delivered for any length of time (S1).
M_{max}	Max. torque	Maximum permissible torque which the motor can deliver for short periods.
M_{dN}	Rated torque	Thermal limiting torque of the motor at rated speed with duty S1
I_{dN}	Rated current	Rated current of the motor (at n_N and M_{dN})
n_N	Rated speed	Rated motor speed
n_{max}	Max. speed	Maximum permissible motor speed
U_{DC}	D.c. link voltage	The d.c. link voltage determines the maximum available output voltage of the converter and thus the motor speed which can be achieved.

Standards, codes and regulations

The servomotors of the DUM/F 6 series are designed in accordance with IEC recommendations and the applicable VDE and DIN standards (see table opposite).

The motors are manufactured in accordance with the international quality standard ISO 9001.

Title	DIN/VDE	EN	IEC
Rotating electrical machines; rating and performance	DIN VDE 0530 Part 1	EN 60 034-1	IEC 600 34-1
Terminal markings and direction of rotation	DIN VDE 0530 Part 8	EN 60 034-8	IEC 600 34-8
Classification of types of construction and mounting arrangements	DIN VDE 0530 Part 7	EN 60 034-7	IEC 600 34-7
Methods of cooling	DIN VDE 0530 Part 6	EN 60 034-6	IEC 600 34-6
Classification of degrees of protection by enclosures	DIN VDE 0530 Part 5	EN 60 034-5	IEC 600 34-5
Mechanical vibration of certain machines – Measurement, evaluation and limits of vibration severity	DIN VDE 0530 Part 14	EN 60 034-14	IEC 600 34-14
Noise limits	DIN VDE 0530 Part 9	EN 60 034-9	IEC 600 34-9
Cylindrical shaft ends for rotating electrical machinery	DIN 748 Part 3		IEC 600 72

Construction, definitions

The servomotors of the DUM/F 6 series are 6- or 8-pole permanent-field synchronous motors with a sine-wave induced voltage. A new compact coil technique ensures a high power density of the motors.

Drive end

In DIN EN 60034-7, the two ends of a motor are defined as follows:



DE: Drive end of the motor

NDE: Non-drive end of the motor

Direction of rotation

When the motor terminals U1, V1, W1 are connected to a supply voltage L1, L2, L3 (with this same phase order) the motor rotates clockwise when viewed facing the D-end.

Nameplate

		WITTUR Electric Drives GmbH				c RU US Inverter Duty VPWM	
DUF6-C1-2BR92-XXXX				Nr.01234567			
U_N 330 V	I_{dN} 3,3 A	n_N 2000 min ⁻¹					
P_N 1,1 kW	M_{dN} 5,2 Nm	f_N 133 Hz					
S1 40°C	155 (F)	IP 65	WED 180-2				
fan 230V / 0,07A / 50/60Hz		brake 24V- / 0,65A / 10Nm					
Made in Germany							

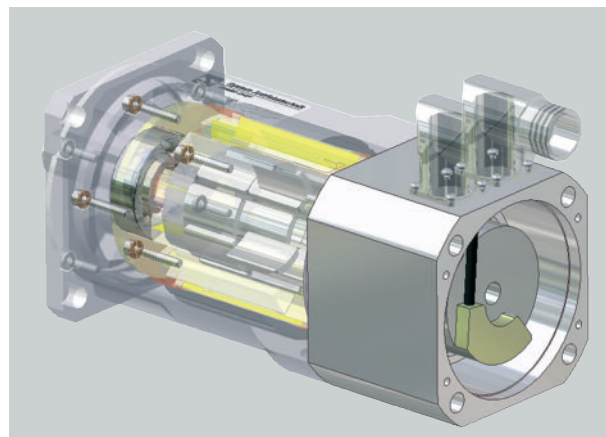
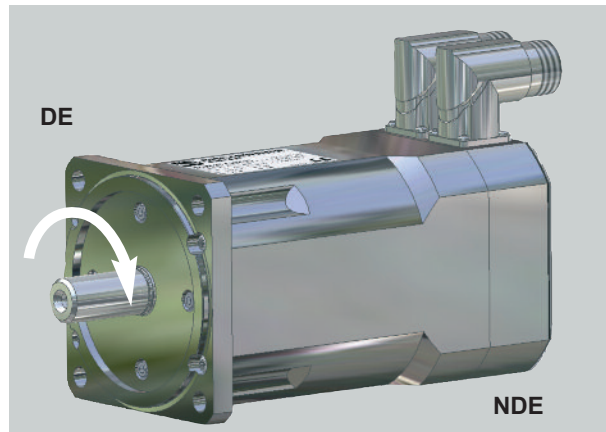

Symbols

M_{d0}	Stall torque (at $n=0$ min ⁻¹)	I_{d0}	Current at stall torque (at $n=0$ min ⁻¹)
M_{d10}	Stall torque (at $n > 10$ min ⁻¹)	I_{d10}	Current at stall torque (at $n > 10$ min ⁻¹)
M_{dN}	Rated torque	I_{dN}	Rated current
P_{dN}	Rated power	n_N	Rated speed
R_{u-v}	Phase-to-phase winding resistance (at 20°C)	L_{u-v}	Phase-to-phase winding inductance
p	Number of pole pairs	k_e	Voltage constant
M_{max}	Max. permissible torque	I_{max}	Max. permissible current
n_{max}	Max. permissible speed	J_L	Rotor inertia
m	Motor weight	f_N	Rated frequency
F_A	Axial force	F_Q	Radial force
R_S	Phase resistance (at 20°C))	L_S	Phase inductance

Installation and operation

Degree of protection

The motors of the DUM/F 6 series are generally designed to meet degree of protection IP65 as specified in DIN EN 60034-5. See table below for the respective sealing.

Shaft sealing	Degree of protection	User information
Diaphragm seal (standard)	IP 64	Exposure to moisture in the shaft and flange area must be kept to a minimum. No liquid may remain in the D end shield, if the motor is mounted with the "shaft end upward" (IM V3, IM V19, IM V36). Shaft outlet is not dustproof.
Rotary shaft seal (option)	IP 65	Suitable for the installation of non-sealed gear units to seal against oil.

Lubrication of the rotary shaft seal



When using a rotary shaft seal, note that the sealing lip needs to be sufficiently lubricated and cooled with a high-quality mineral oil such as SAE 20 to ensure the proper functioning of the seal. Sufficient lubricant supply is required for proper heat dissipation.

If the shaft seal is greased, the maximum permissible motor speed may need to be reduced.

Regular regreasing is imperative!

Excessive peripheral speeds destroy the sealing lip and its protective function is no longer guaranteed.

Cooling, altitude, ambient conditions

The rated power (rated torque) applies to continuous operation (duty type S1) at a coolant temperature of 40°C and an altitude of up to 1,000 m a.s.l. It is determined by using defined aluminium test flanges.

If the motor flange is thermally insulated, it is not able to dissipate the motor heat. This requires a reduction of the rated motor torque.

At higher temperatures or altitudes, the overload capability of the motors is reduced (see table opposite).

Motor type	Test flange dimensions
DUM 6-A	200 x 100 x 10
DUM 6-B	232 x 232 x 19
DUM/F 6-C	232 x 300 x 19
DUM/F 6-D	370 x 370 x 19
DUM/F 6-E	410 x 396 x 23

A.s.l. [m]	Coolant temperature [°C]					
	<30	30-40	45	50	55	60
1000	1.07	1.00	0.96	0.92	0.87	0.82
1500	1.04	0.97	0.93	0.89	0.84	0.79
2000	1.00	0.94	0.90	0.86	0.82	0.77
2500	0.96	0.90	0.86	0.83	0.78	0.74
3000	0.92	0.86	0.82	0.79	0.75	0.70
3500	0.88	0.82	0.79	0.75	0.71	0.67
4000	0.82	0.77	0.74	0.71	0.67	0.63



Surface temperatures of more than 100°C may occur on the motors. Therefore, no temperature-sensitive parts must be allowed to come into contact or be attached to them.

If the motor is equipped with a separately driven fan, connect the fan properly and check the direction of rotation (arrow on the fan housing). Make sure that the rotation of the fan wheel is not obstructed.

The different cycle frequencies of the electronic converter output stages may require the motor to be derated, resulting from an increased harmonic content.

Shaft ends

Motors of the DUM/F 6 series have cylindrical shaft ends to DIN 748. As an option, the shaft end is also available with a keyway to DIN 6885, Part 1.

Use suitable devices for mounting and pulling off driving elements such as gears, pulleys, couplings, etc. Support the device at the DE shaft end.



Do not expose the motor to any impacts or blows.

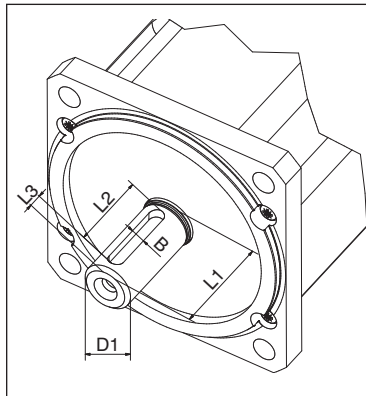

Motor type	Shaft end		Keyway		
	D1	L1	B	L2	L3
DUM 6-A	Ø 9 k6	20	3	12	4
DUM 6-B	Ø 14 k6	30	5	22	3
DUM/F 6-C	Ø 19 k6	40	6	32	4
DUM/F 6-D	Ø 24 k6	50	8	40	5
DUM/F 6-E	Ø 32 k6	58	10	50	5

Holding brake

The optional built-in holding brake is used to fix the motor shaft when the motor is at rest or de-energised. It is a permanent-field single-disc brake which operates on the closed-circuit principle, i.e. the brake is effective when the motor is de-energised, thus braking the motor shaft.



The holding brake is not a working brake.

Holding brakes are operated on d.c. current. The nominal voltage is 24 V. They can be connected to a central d.c. voltage supply. Overvoltages, even transient, are not permitted since they deteriorate the permanent magnets irreversibly. The excitation current ripple must be less than 20% to ensure reliable opening of the brake and prevent disturbing humming noises.

Since the holding brakes are permanent-magnet brakes, be sure to observe the correct polarity of the d.c. voltage, otherwise the brake will not open.



Modern (field-oriented) frequency converters are able to produce a high torque even at low motor speeds. If the converter has a sufficient current reserve, a multiple of the rated motor torque can be produced. In this case the motor shaft may turn even if the holding brake is applied, because the holding torque of the brake is exceeded.

Suppressor circuit

If the excitation current of the holding brake is switched off on the d.c. side, a voltage peak occurs which can be higher than 1,000 V. It is caused by the inductance of the holding brake. A varistor R should be connected in parallel to the coil to prevent this voltage peak. Recommended type: Q69-X3022 (S 14 K 30).

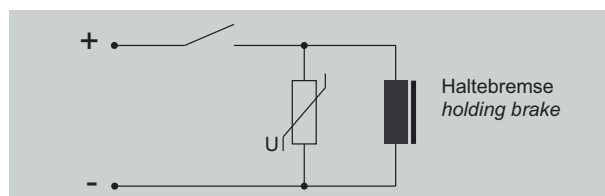

Winding, insulation system

The insulation materials we use ensure insulation class 155 (F) to DIN EN 60034. Therefore, the winding temperature rise may be max. 105 K at a coolant temperature of +40 °C. We also use insulation materials with the temperature profile T1200 of class 180 (H) to increase the reliability of the motors.

The insulation system of the motors is designed such that they can be connected to a converter with a maximum d.c. link voltage U_{link} max. up to max. 700 Volt.

Note: $U_{link max.}$ is the maximum value of the d.c. link voltage which is only transient and approximately equivalent to the inception voltage of the braking chopper or of the energy recovery unit.

The maximum permissible rate of voltage rise (dU/dt) at the motor terminals may be max. 4 kV/μs. The overvoltage at the motor terminals must not exceed 1.56 kV. It may be necessary to use motor current filters or reactors to achieve these values.



The motors are not designed for direct connection to the three-phase system but have to be operated via an electronic converter. Direct connection to the system may destroy the motor.

Separately driven fan

The motors DUF are forced-air-cooled by an axial fan. The connection data are given on the motor nameplate. The necessary terminal plug is included in the delivery of the motor.

Motor type	Rated voltage	Rated torque	Degree of protection
DUF 6-C...	230 V (+6%/-10%) 50/60 Hz	0.12 A	IP 54
DUF 6-D...	230 V (+6%/-10%) 50/60 Hz	0.30 A	IP 54
DUF 6-E...	3 x 400 V (+6%/-10%) 50/60 Hz	0,15 A	IP 44

Conductor size

The recommended values for the dimensioning of the conductor cross-sections are given in the table. They are specified in DIN VDE 0113 (EN 60 204) "Electrical equipment of industrial machines" for the current carrying capacity of PVC-insulated cables with copper conductor routed in cable ducts. The maximum permissible ambient temperature is +40 °C.

Conductor size [mm ²]	perm. maximum current [A]
0.75	7.8
1.0	9.6
1.5	14.4
2.5	18.3
4.0	25.0
6.0	32.0
10.0	43.0
16.0	58.0

Speed and shaft position measuring system/resolver

The DUM6 motors are equipped with 2-pole resolvers, size 15, for speed and shaft position control..

Technical data	
Number of poles	2
Transformation ratio	0.5 ± 5%
Input voltage/frequency	7 V / 10 kHz
Input current	65 mA max.
Electrical error	±10' max.
Phase displacement	0° nom.

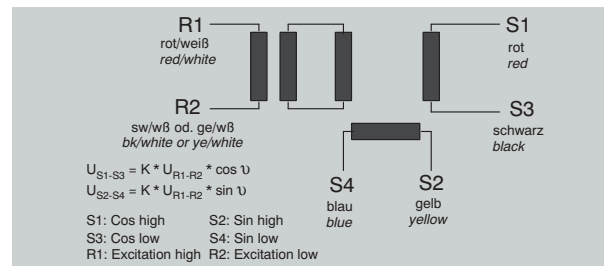

The measuring system of synchronous motors (DUM6) must be adjusted to the respective converter. Any misadjustment may lead to uncontrolled motor response or complete failure of the motor.

Note: 2-pole resolvers are installed as standard. Other resolver pole numbers or other measuring systems are available (e.g. absolute sine-cosine encoders).

Monitoring the winding temperature

PTC thermistors are installed as standard in the DE winding head to protect the winding from thermal overload when the temperature change is slow (temperature change in minutes or hours).

The maximum operating voltage of the PTC thermistors must not exceed 30V-.

Due to the non-ideal thermal coupling, the temperature sensor follows rapid winding temperature changes only with delay, thus being unable to protect the winding if the thermal overload of the motor is transient and high. Therefore, additional protection is required (such as monitoring $I^2 \times t$ by the converter electronic system) to protect the motor from fast-rising thermal overload.



The evaluation of the temperature sensor belongs to the monitoring of the motor winding. The temperature sensor follows rapid temperature changes only with delay. Especially the windings of small motors (DUM6-Ax and DUM6-Bx) are very sensitive to overload.

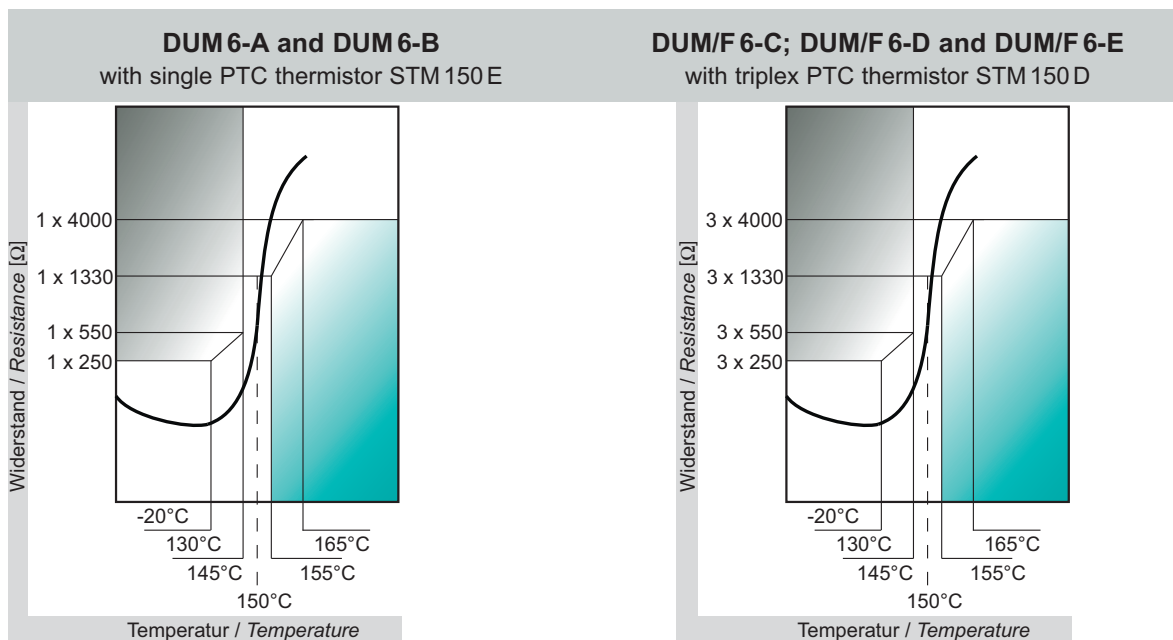

Note: The built-in PTC thermistor is the basic version. Other temperature detectors such as KTY 84 or miniature thermal time-delay switches are available as an option.

The maximum motor current must be limited to ensure that the temperature sensor trips quickly enough. (See the following diagrams to adjust the recommended current limits.) If a higher current limit needs to be adjusted, the current must not exceed the current-time values shown in the characteristics and the motor max. current I_{max} .



The characteristics apply in case of a failure. They must not be applied for normal motor operation. The r.m.s. value of the motor current is not permitted to exceed the nominal continuous current I_{dN} within any cycle!

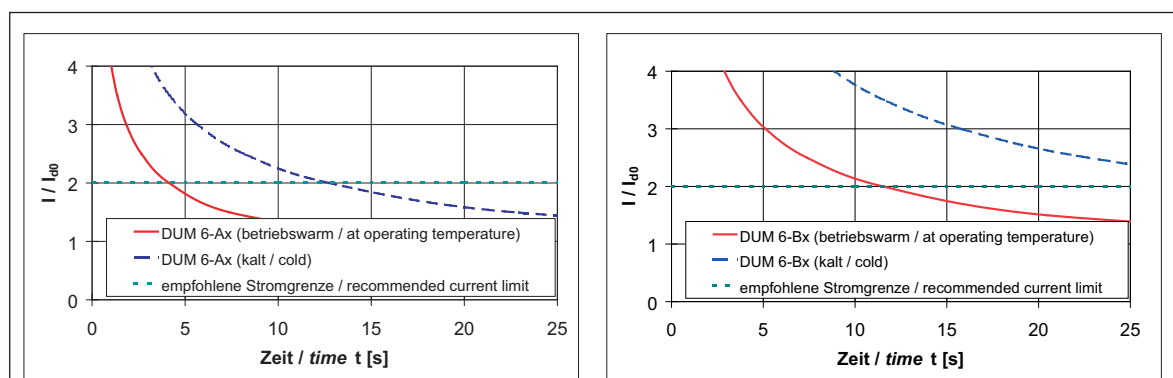

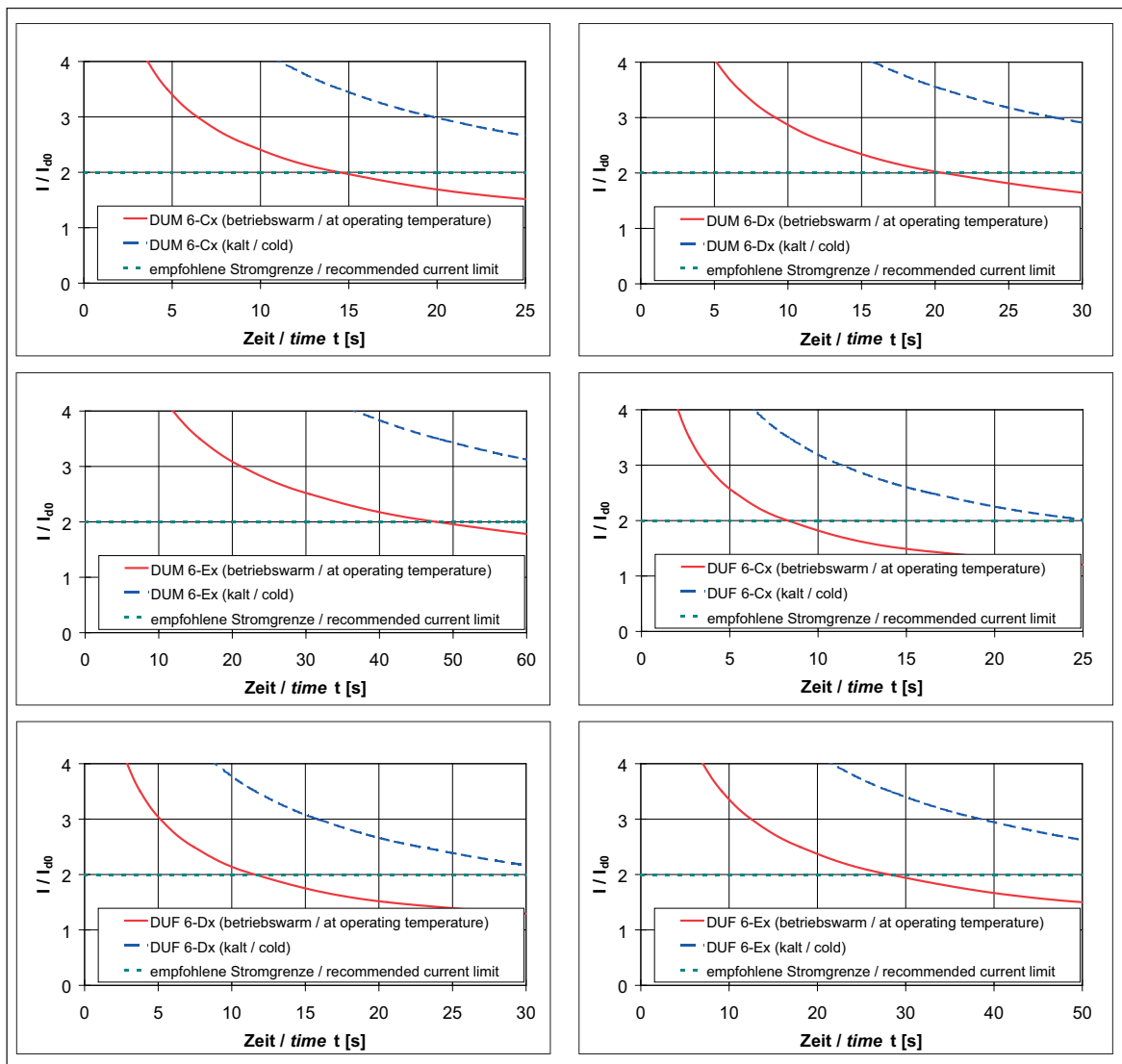

Transport and packaging

The packaging and transport technologies are dependent on the shipping conditions. The following types of packaging are provided:

- Folding boxes
- Covered and steel-strapped flat pallets (transport by lorry)
- Special pallets
- Special packaging in wooden cases

The motors should always be shipped so that no damage can occur in transit.



Avoid any impacts, sharp sudden movements and strong vibrations during transport. Operate the crane only at creeping speed to lift or place down the motors. This prevents damage to the bearings or the machine.

The motors leave the factory in a faultless condition after being tested.

Make a visual check for any external damage immediately upon their arrival on site. If any damage caused in transit is found, make a notice of claim in the presence of the forwarder. In addition, report the damage to the manufacturer at the latest within one week. Do not put these motors into operation.

Storage

If the motors are not installed immediately after their arrival, they should be properly stored.

Store the motors only in closed, dry, dust-free, well-ventilated and vibration-free rooms. Damp rooms are unsuitable for storage! Do not remove the anti-corrosive coat from the shaft ends, flange surfaces, etc. Check it at certain intervals depending on the ambient conditions, and touch up, if required.

Take care that no vibrations occur in storage to prevent the anti-friction bearings from being damaged. It is advisable to turn the rotor several times at certain intervals to prevent corrosion of the bearings.

After prolonged storage (>3 months), rotate the motor in both directions at a low speed ($\leq 100 \text{ min}^{-1}$) to allow the grease to distribute evenly in the bearings.

Maintenance



Repairs may only be carried out by the manufacturer or an authorised repair agency. Unauthorised opening and tampering may lead to injuries to persons and property and may lead to a loss of warranty rights.

Safety instructions

Before starting any work on the motors, and particularly before opening any covers of active parts, make sure that the motor and plant have been properly isolated.

This refers also to any additional or auxiliary circuits.

The "5 safety rules" to be applied according to DIN VDE 0105 are:

- Disconnect the motor.
- Lock it against unintentional restarting.
- Verify the safe isolation from supply.
- Earth and short (with voltages above 1,000V).
- Safeguard or cover adjacent live parts.

Maintenance intervals

Careful and regular maintenance and inspections are required to recognise and remedy troubles in good time, before they lead to major damage.

Since the operating conditions of the motors differ considerably, only general maintenance intervals to ensure trouble-free operation can be specified. They need to be adapted to the local conditions such as the actual level of contamination, number of starts, load, etc.

- Clean the motor, depending on the local level of contamination.
- Retighten the electrical and mechanical connections. Check for deterioration of running smoothness or bearing noise: after approx. 500 operating hours, but after 1 year at the latest.
- With rotary shaft seal option only: Regrease the rotary shaft seal depending on the operating mode every 50 to 500 operating hours (applies only to grease lubrication!).

Permissible axial and radial forces

The maximum permissible axial and radial forces must not be exceeded in order to ensure smooth running of the motor.

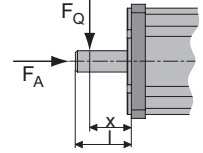

Axial forces

The following forces $F_{A\text{permiss.}}$ are permitted in axial direction with the radial force F_Q acting simultaneously

Motortyp	Axial forces $F_{A\text{permiss.}}$ [N] at speeds n [min ⁻¹] (with $F_Q \neq 0$)							
	1,000	1,500	2,000	3,000	4,000	4,500	6,000	9,000
DUM6-A1								
DUM6-A2			130	105	95		80	70
DUM6-A3								
DUM6-A4								
DUM6-B1								
DUM6-B2			230	195	175		150	130
DUM6-B3								
DUM/F 6-C1								
DUM/F 6-C2			310	260	230		200	
DUM/F 6-C3								
DUM/F 6-C4								
DUM/F 6-D1								
DUM/F 6-D2			330	280		240		
DUM/F 6-D3								
DUM/F 6-D4								
DUM/F 6-E1								
DUM/F 6-E2	890	780	700	590	520			
DUM/F 6-E3								

$$F_{A\text{ges.}} = F_A + F_W$$

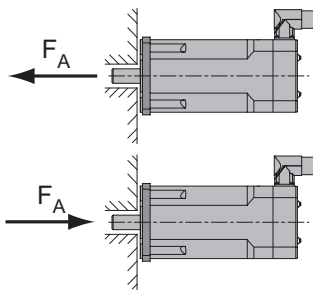

$$F_{A\text{ges.}} = F_A$$

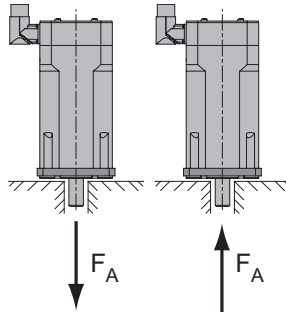

$$F_{A\text{ges.}} = F_A + F_G + F_W$$

$$F_{A\text{ges.}} = F_A - F_G$$

$$F_{A\text{ges.}} = F_A - F_G + F_W$$

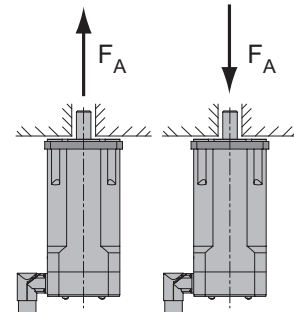

$$F_{A\text{ges.}} = F_A + F_G$$

Constructin type	B5	V1	V3
------------------	----	----	----

Depending on the mounting arrangement of the motors and the direction of the effective axial force F_A , the rotor inertial force F_G and the force of the ondular washer F_W must be taken into consideration. The total effective axial force $F_{A\text{ges.}}$ is calculated as shown in the above figure.

Motor type	F_W [N]	F_G [N]
DUM6-A1		2
DUM6-A2		3
DUM6-A3	90	4
DUM6-A4		5
DUM6-B1		5
DUM6-B2	110	7
DUM6-B3		9

Motor type	F_W [N]	F_G [N]
DUM/F 6-C1		13
DUM/F 6-C2		17
DUM/F 6-C3	110	20
DUM/F 6-C4		24
DUM/F 6-D1		25
DUM/F 6-D2		31
DUM/F 6-D3	150	37
DUM/F 6-D4		43
DUM/F 6-E1		65
DUM/F 6-E2	435	80
DUM/F 6-E3		95

Radial forces

The endurance strength of the shaft and the bearing life are decisive for the permissible radial load. Taking the endurance strength into consideration, F_Q is not permitted to be exceeded even during dynamic processes (acceleration, braking).

DUM 6-A

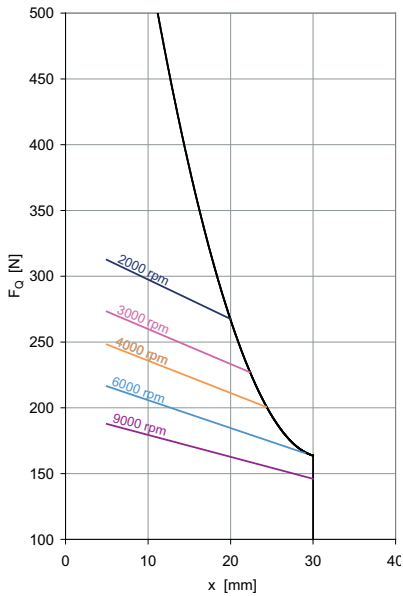

DUM 6-B

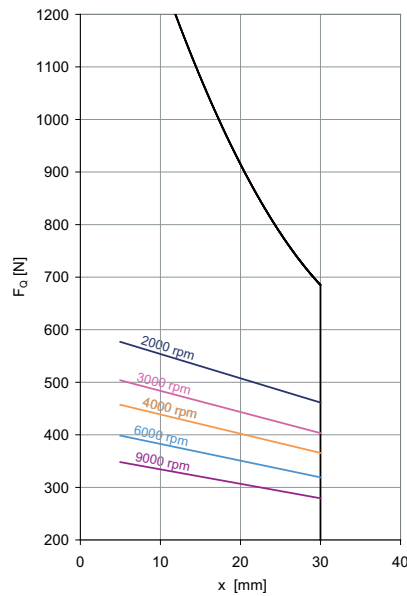

DUM/F 6-C

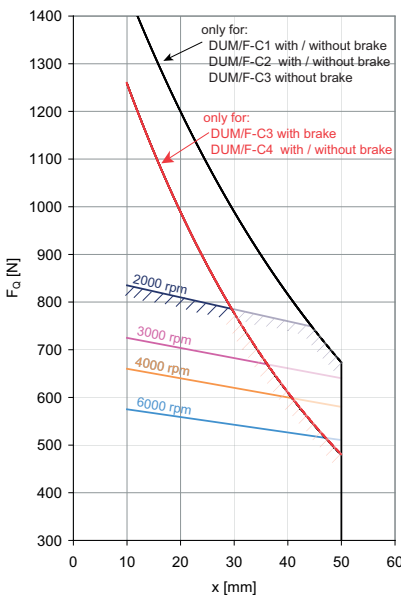

DUM/F 6-D

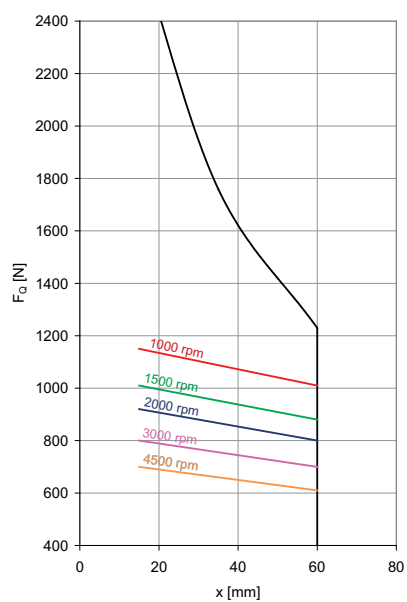

DUM/F 6-E

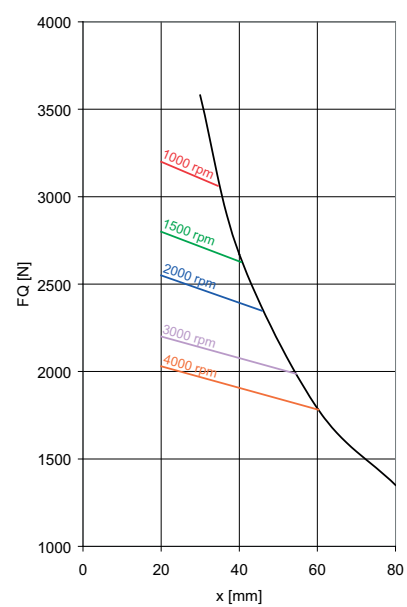

Connection system DUM/F 6-A...D

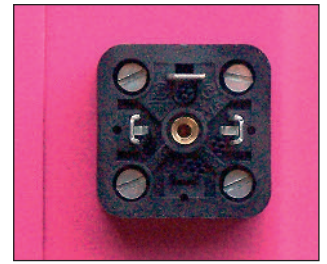
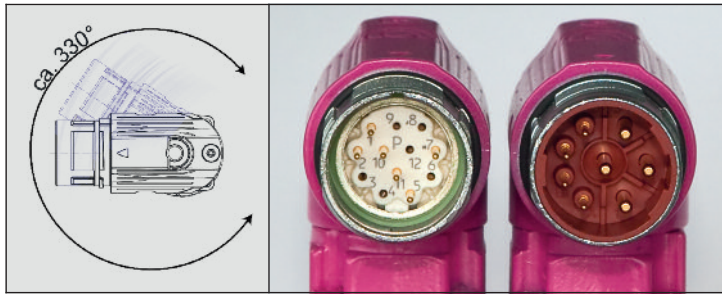

	Encoder connection	Connection to system	Fan connection
Socket type	12-pin rotatable angle socket	8-pin rotatable angle socket	Connector plug (2-pole + ground wire)
Recommended connector	ASTA 021 FR01 12 0035 000	B STA 108 FR05 08 0036 000	included in delivery
Pinning configuration (view of motor connecting pins)			
Pin assignment	<ul style="list-style-type: none"> 1 - S4 SIN - 2 - S1 COS + 5 - R1 REF + 7 - R2 REF - 10 - S2 SIN + 11 - S3 COS - 	<ul style="list-style-type: none"> 1 - U1 2 - PE 3 - W1 4 - V1 A - brake + (if any) B - brake - (if any) C - temperature detector + D - temperature detector - 	<ul style="list-style-type: none"> 1 - L1 2 - N 3 - PE

Accessories

	Encoder connection	Connection to system
Cable sets (shielded, trailing: to customer spec.)		
Cable connector	12-pin connector ASTA 021 FR01 12 0035 000	8-pin connector B STA 108 FR05 08 0036 000

Connection system DUM/F 6-E



Encoder connection

Connection to system

Socket type	12-pin rotatable angle socket	8-pin rotatable angle socket	Connector plug (3-pole + ground wire)
Recommended connector	A STA 021 FR01 12 0035 000	C ST A264 FR48 45 0001 000	included in delivery

Pinning configuration (view of motor connecting pins)

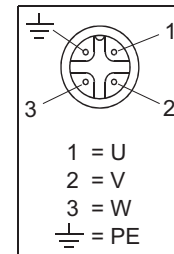
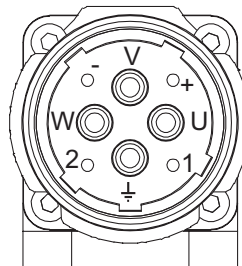
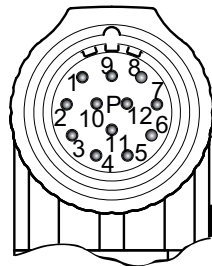

Pin assignment

1 - S4 SIN -	U - U1	1 - U
2 - S1 COS +	V - V1	2 - V
5 - R1 REF +	W - W1	3 - W
7 - R2 REF -	PE - PE	4 - PE
10 - S2 SIN +	+ - brake + (if any)	
11 - S3 COS -	- - brake - (if any)	
	1 - temperature detector +	
	2 - temperature detector -	

Accessories

Encoder connection

Connection to system

Cable sets (shielded, trailing: to customer spec.)



Cable connector

12-pin connector
A STA 021 FR01 12 0035 000

8-pin connector
C ST A264 FR48 45 0001 000

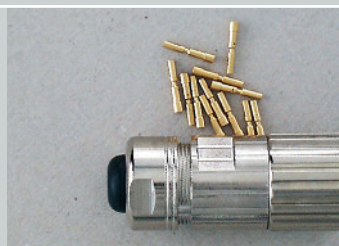

Type code

Example:	DU	M	6-	A	3	-	2	0	R9	6	-	000	A
	DU	B3	6-	Z2	Z3	-	X1	X2	X3	X4	-	X5	X7
B3: Construction type:													
	<i>M – flange, self-cooling</i> <i>F – flange, enforced-cooling</i>												
Z2: Mounting window:													
	<i>A - 55 mm B - 75 mm C - 95 mm</i> <i>D - 127 mm D - 194 mm</i>												
Z3: Overall length:													
	1, 2, 3, 4												
X1: Voltage variant:													
	2 - for supply voltages U_N from 400 V												
X2: Holding brake:													
	0 - no brake 4 - permanent-field holding brake												
X3: Measuring system:													
	<i>A8 - ECI/EQI 1300 (Heidenhain)</i> <i>AA - AD 34 (Hengstler)</i> <i>I8 - ERN 1387 (Heidenhain)</i> <i>IN - ERN 1185 (Heidenhain)</i> <i>IR - SRS 50/52 K (Sick-Stegmann)</i> <i>IW - SKS/SKM 36 (Sick-Stegmann)</i> <i>R9 - Resolver Size 15 (2, 6 or 8-pole)</i>												
X4: Rated speed:													
	0 - 1,000 min^{-1} 1 - 1,500 min^{-1} 2 - 2,000 min^{-1} 3 - 3,000 min^{-1} 4 - 4,000 min^{-1} 6 - 6,000 min^{-1}												
X5: Modifications:													
	000 - Standard												
X7: Measuring system type, pin assignment (together with X3):													
	A - with X3 = R9: 2-pole resolver; standard pin assignment												



WITTUR Electric
Drives GmbH



Technical data DUM 6-A...

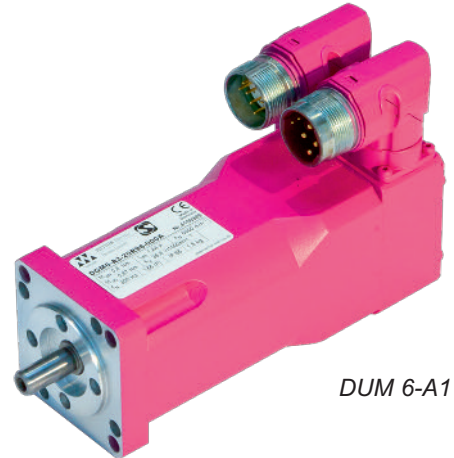

DUM 6-A1

for supply voltages U_N from 400 V

Motor type			DUM 6-A1- 2xx6	DUM 6-A2- 2xx6	DUM 6-A3- 2xx6	DUM 6-A4- 2xx6
Stall torque	M_{d0}	[Nm]	0.47	0.66	0.87	1.14
Current at stall torque	I_{d0}	[A]	0.94	1.24	1.43	1.55
Stall torque	M_{d10}	[Nm]	0.48	0.68	0.89	1.17
Current at stall torque	I_{d10}	[A]	1.02	1.28	1.48	1.70
Number of poles	2p		6			

Nominal rating

Rated torque	M_{dN}	[Nm]	0.43	0.62	0.80	1.05
Rated current	I_{dN}	[A]	0.93	1.16	1.44	1.64
Rated speed	n_N	[min ⁻¹]	6000	6000	6000	6000
Rated power	P_{dN}	[kW]	0.27	0.39	0.50	0.66
Voltage constant ¹⁾	k_e	[V/1000min ⁻¹]	31.2	34.1	35.8	41.5
Winding resistance ²⁾	R_{u-v}	[Ω]	37.4	24.0	17.8	12.6
Winding inductance	L_{u-v}	[mH]	19.0	13.1	11.5	9.6

Max. values

Max. torque	M_{max}	[Nm]	2.1	2.9	3.8	5.0
Max. current (peak value)	I_{max}	[A]	4.5	5.6	6.9	8.0
Max. speed	n_{max}	[min ⁻¹]	9,000			

Mechanical data ³⁾

Inertia	J_L	[kgcm ²]	0.13	0.18	0,23	0.34
Weight	m	[kg]	1.0	1.2	1.4	1.9
Overall length	l_{38}	[mm]	121	133	145	170

¹⁾ at operating temperature

²⁾ at 20°C

³⁾ with resolver size 15 (X3=R9), without holding brake

Measuring systems (X3):

R9 Resolver Size 15 (2- or 6-poe)
 IN ERN 1185 (Heidenhain)
 IW SKS/SKM 36 (Sick-Stegmann)

Dimensions

Motor type	without holding brake				with holding brake			
	with resolver (R9)		with encoder (IN / IW)		with resolver (R9)		with encoder (IN / IW)	
	l_{38}	r	l_{38}	r	l_{38}	r	l_{38}	r
DUM6-A1	121	105	156	136	145	129	180	160
DUM6-A2	133	117	168	148	157	141	192	172
DUM6-A3	145	129	180	160	169	153	204	184
DUM6-A4	170	153	205	185	194	178	229	209

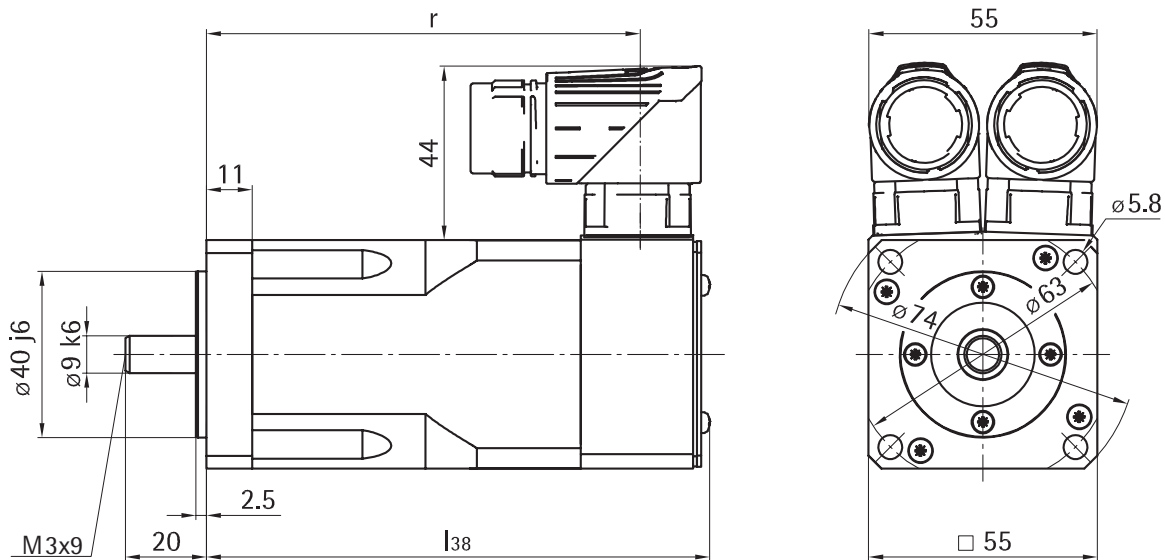

Speed-torque characteristics

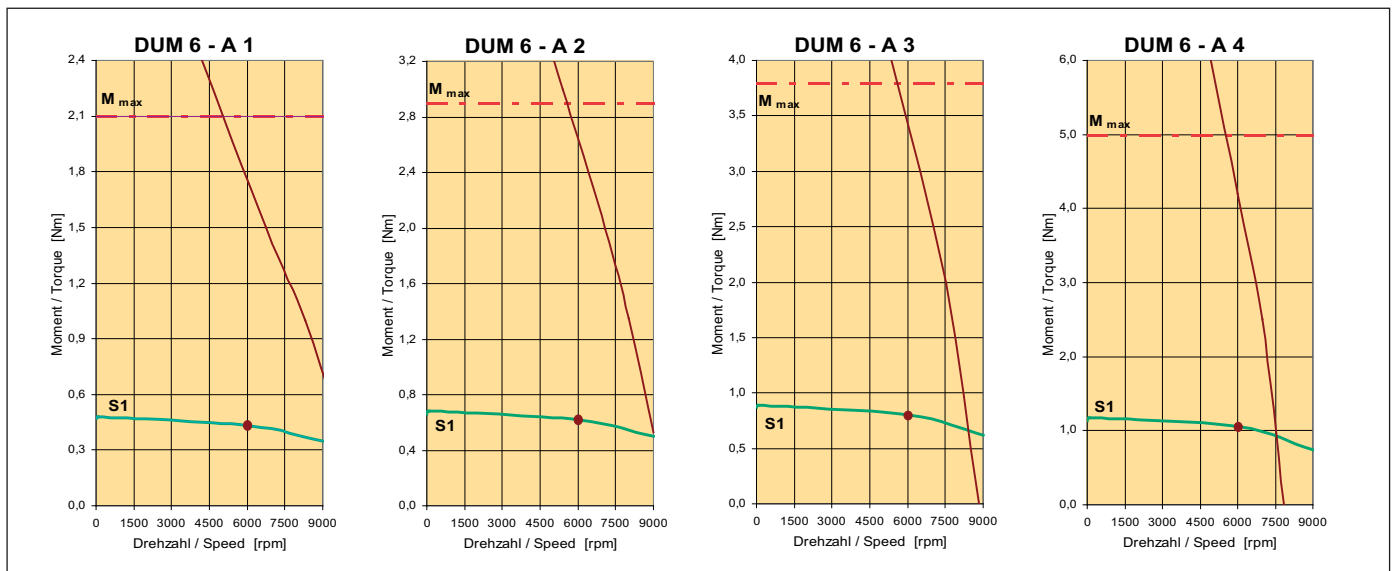

Holding brake

Holding torque	M_{Br}	[Nm]	1.1
Rated voltage	U_{Br}	[V]	24
Rated current (20°C)	I_{Br}	[A]	0.31
Weight	m	[kg]	0.16
Rotor inertia	J_{Br}	[kgcm ²]	0.07

Technical data DUM 6-B...

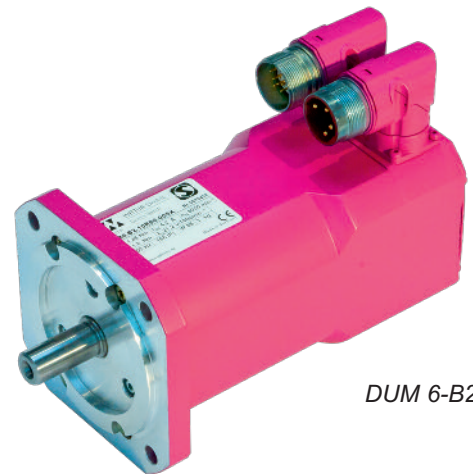

DUM 6-B2

for supply voltages U_N from 400 V

Motor type			DUM 6-B1-			DUM 6-B2-			DUM 6-B3-		
			2xx3	2xx4	2xx6	2xx3	2xx4	2xx6	2xx3	2xx4	2xx6
Stall torque	M_{d0}	[Nm]	0.92			1.8			2.6		
Current at stall torque	I_{d0}	[A]	1.0	1.2	1.5	1.6	2.0	2.5	2.3	2.7	3.9
Stall torque	M_{d10}	[Nm]	0.94			1.84			2.65		
Current at stall torque	I_{d10}	[A]	1.0	1.2	1.5	1.6	2.0	2.6	2.4	2.8	4.1
Number of poles	2p		6								

Nominal rating

Rated torque	M_{dN}	[Nm]	0.9	0.87	0.76	1.83	1.75	1.5	2.6	2.5	2.3
Rated current	I_{dN}	[A]	1.0	1.2	1.3	1.7	2.1	2.3	2.6	2.9	3.6
Rated speed	n_N	[min ⁻¹]	3000	4000	6000	3000	4000	6000	3000	4000	6000
Rated power	P_{dN}	[kW]	0.28	0.37	0.48	0.58	0.73	0.94	0.83	1.03	1.35
Voltage constant ¹⁾	k_e	[V/1000min ⁻¹]	54.1	44.4	35.4	64.0	51.0	39.6	61.5	52.6	36.4
Winding resistance ²⁾	R_{u-v}	[Ω]	37.2	24.6	15.7	17.7	11.1	6.9	9.3	7.6	3.4
Winding inductance	L_{u-v}	[mH]	66.0	44.4	28.3	41.4	26.3	15.9	25.1	18.4	8.8

Max. values

Max. torque	M_{max}	[Nm]	2.7			5.4			7.8		
Max. current (peak value)	I_{max}	[A]	3.6	4.5	5.5	6.1	7.7	9.9	9.2	10.8	15.5
Max. speed	n_{max}	[min ⁻¹]	9000								

Mechanical data ³⁾

Inertia	J_L	[kgcm ²]	0.30			0.56			0.79		
Weight	m	[kg]	2.3			3.0			3.7		
Overall length	l_{38}	[mm]	132			158			184		

¹⁾ at operating temperature

²⁾ at 20°C

³⁾ with resolver size 15 (X3=R9), without holding brake

Measuring systems (X3):

A8	ECI/EQI 1300 (Heidenhain)
I8	ERN 1387 (Heidenhain)
IN	ERN 1185 (Heidenhain)
IR	SRS/SRM 50 (Sick-Stegmann)
IW	SKS/SKM 36 (Sick-Stegmann)
R9	Resolver Size 15 (2- or 6-pole)

Dimensions

Motor type	without holding brake				with holding brake			
	with resolver (R9)		with encoder (A8, I8, IN, IR, IW)		with resolver (R9)		with encoder (A8, I8, IN, IR, IW)	
	l_{38}	r	l_{38}	r	l_{38}	r	l_{38}	r
DUM6-B1	132	113	174	148	164	145	206	180
DUM6-B2	158	139	200	174	190	171	232	206
DUM6-B3	184	165	226	200	216	197	258	232

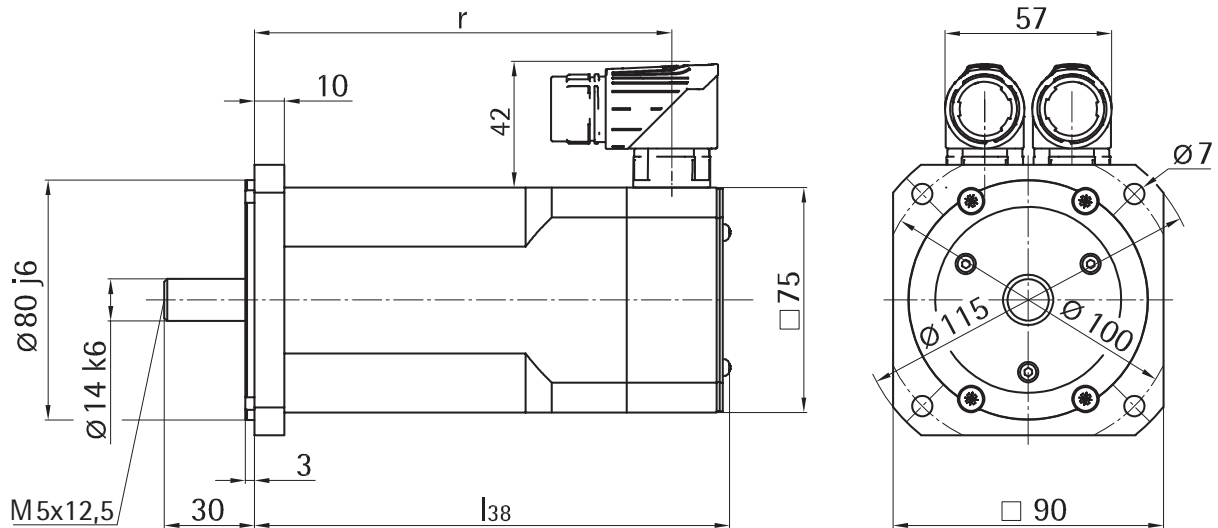

Speed-torque characteristics

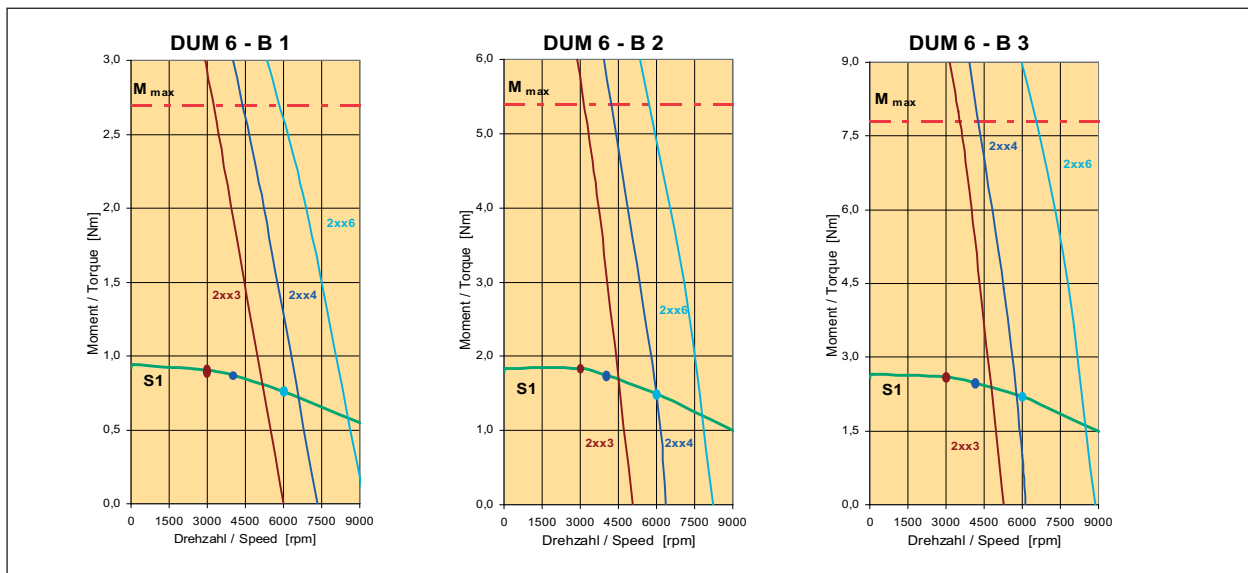

Holding brake

Holding torque	M_{Br}	[Nm]	3.2
Rated voltage	U_{Br}	[V]	24
Rated current (20°C)	I_{Br}	[A]	0.45
Weight	m	[kg]	0.3
Rotor inertia	J_{Br}	[kgcm ²]	0.38

Technical data DUM 6-C...

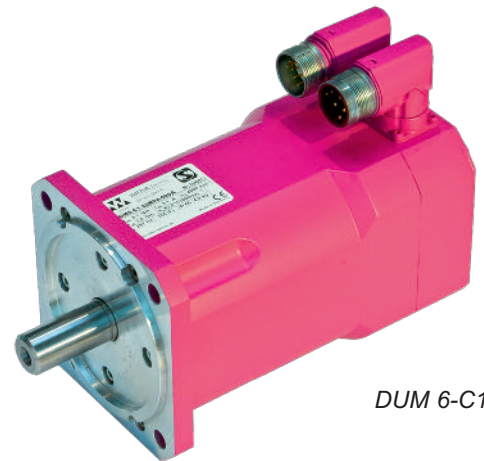

DUM 6-C1

for supply voltages U_N from 400 V

Motor type	DUM 6-C1-			DUM 6-C2-			DUM 6-C3-			DUM 6-C4-					
	2xx2	2xx3	2xx4	2xx2	2xx3	2xx4	2xx2	2xx3	2xx4	2xx2	2xx3	2xx4			
Stall torque	M_{d0}		[Nm]	3.9			5.7			7.1			8.5		
Current at stall torque	I_{d0}		[A]	2.5	3.1	3.9	3.8	5.0	6.1	5.7	7.0	8.8	5.5	8.5	10.7
Stall torque	M_{d10}		[Nm]	4.0			5.8			7.2			8.6		
Current at stall torque	I_{d10}		[A]	2.5	3.1	3.9	3.8	5.1	6.2	4.5	5.5	6.9	4.3	6.7	8.4
Number of poles	2p			8											

Nominal rating

Rated torque	M_{dN}		[Nm]	3.8	3.5	3.1	5.5	4.8	4.2	6.9	6.4	5.7	8.3	7.6	6.8
Rated current	I_{dN}		[A]	2.5	2.8	3.1	3.7	4.2	4.5	4.3	4.9	5.5	4.2	6.0	6.6
Rated speed	n_N		[min ⁻¹]	2000	3000	4000	2000	3000	4000	2000	3000	4000	2000	3000	4000
Rated power	P_{dN}		[kW]	0.8	1.1	1.3	1.2	1.5	1.8	1.4	2.0	2.4	1.7	2.4	2.8
Voltage constant ¹⁾	k_e		[V/1000min ⁻¹]	98.3	78.9	62.9	92.5	69.4	57.0	97.9	79.5	63.4	122	79.1	63.3
Winding resistance ²⁾	R_{u-v}		[Ω]	11.6	7.4	4.7	6.1	3.6	2.4	4.4	2.9	1.8	5.3	2.2	1.4
Winding inductance	L_{u-v}		[mH]	29.5	19.0	12.1	16.5	9.3	6.3	13.5	8.9	5.7	20.0	8.4	5.4

Max. values

Max. torque	M_{max}		[Nm]	12			17.5			22			26		
Max. current (peak value)	I_{max}		[A]	8.4	10.5	13.2	12.6	16.8	20.4	16.2	20.0	25.1	15.3	23.8	29.6
Max. speed	n_{max}		[min ⁻¹]	6000											

Mechanical data ³⁾

Inertia	J_L		[kgcm ²]	2.7			3.7			4.7			6.0		
Weight	m		[kg]	4.8			6.3			7.4			8.6		
Overall length	l_{38}		[mm]	178			206			234			262		

¹⁾ at operating temperature

²⁾ at 20°C

³⁾ with resolver size 15 (X3=R9), without holding brake

Measuring systems (X3):

- A8 ECI/EQI 1300 (Heidenhain)
- I8 ERN 1387 (Heidenhain)
- IR SRS/SRM 50 (Sick-Stegmann)
- IW SKS/SKM 36 (Sick-Stegmann)
- R9 Resolver Size 15 (2- or 6-pole)

Dimensions

Motortyp	without holding brake				with holding brake			
	with resolver (R9)		with encoder (A8, I8, IR, IW)		with resolver (R9)		with encoder (A8, I8, IR, IW)	
	l_{38}	r	l_{38}	r	l_{38}	r	l_{38}	r
DUM6-C1	178	158	220	193	214	194	256	229
DUM6-C2	206	186	248	221	242	222	284	257
DUM6-C3	234	214	276	249	270	250	312	285
DUM6-C4	262	242	304	277	298	278	340	313

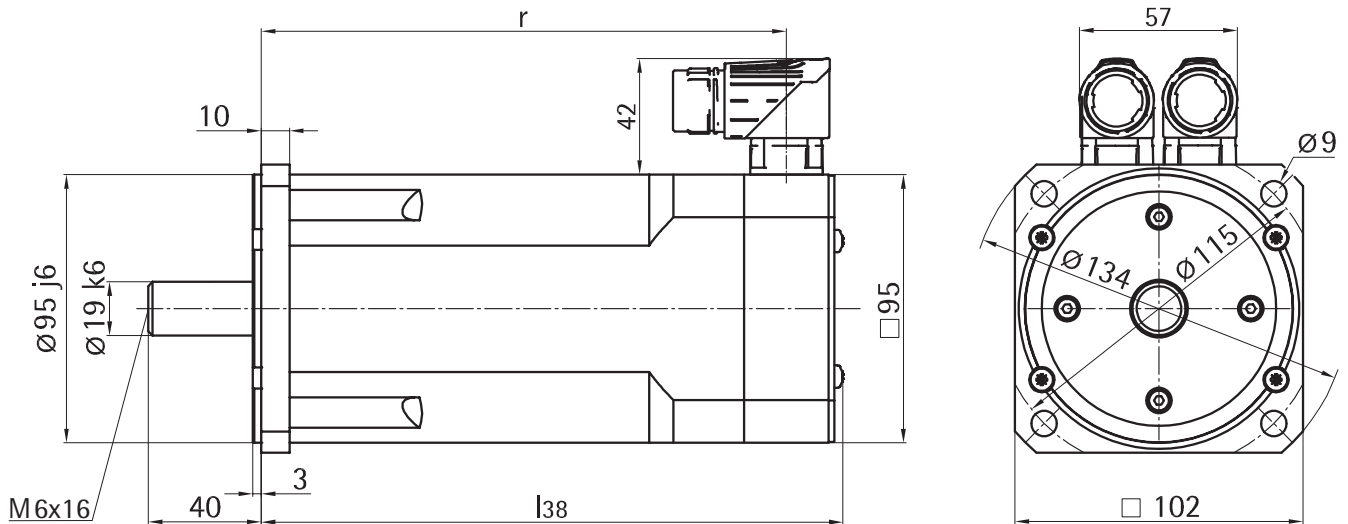

Speed-torque characteristics

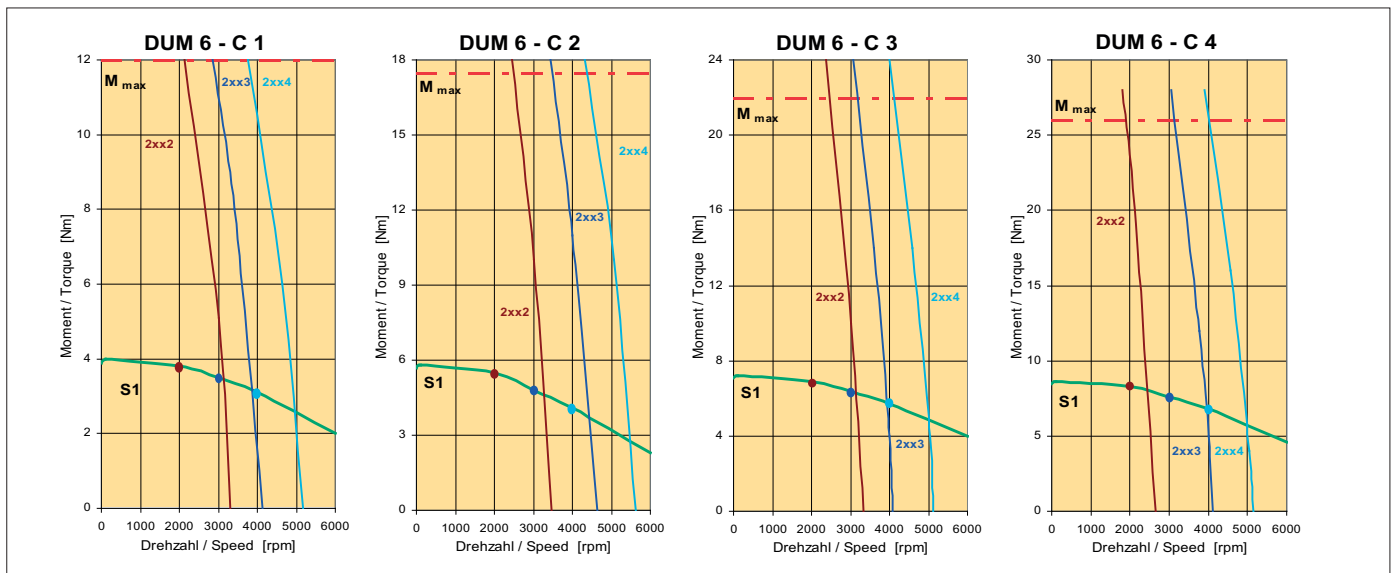

Holding brake

Holding torque	M_{Br}	[Nm]	10
Rated voltage	U_{Br}	[V]	24
Rated current (20°C)	I_{Br}	[A]	0.65
Weight	m	[kg]	0.7
Rotor inertia	J_{Br}	[kgcm ²]	1.07

Technical data DUM 6-D...

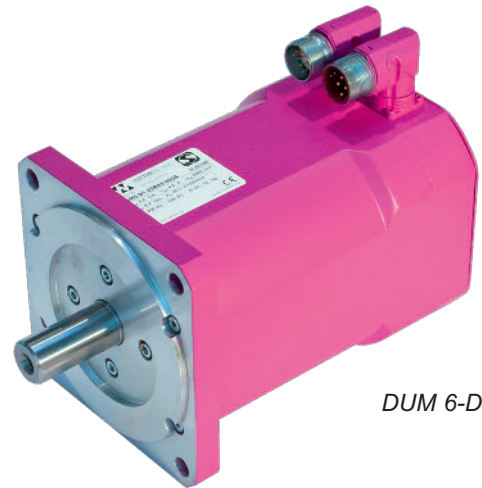

DUM 6-D1

for supply voltages U_N from 400 V

Motor type			DUM 6-D1-			DUM 6-D2-			DUM 6-D3-			DUM 6-D4-		
			2xx1	2xx2	2xx3	2xx1	2xx2	2xx3	2xx1	2xx2	2xx3	2xx1	2xx2	2xx3
Stall torque	M_{d0}	[Nm]	8.2			11.6			15.3			18.4		
Current at stall torque	I_{d0}	[A]	3.6	4.6	6.0	5.6	6.9	8.9	6.8	8.8	11.2	8.2	10.4	14.0
Stall torque	M_{d10}	[Nm]	8.3			11.8			15.6			18.8		
Current at stall torque	I_{d10}	[A]	3.3	4.2	5.5	5.1	6.2	8.1	6.1	7.9	10.2	7.4	9.5	12.7
Number of poles	2p		8											

Nominal rating

Rated torque	M_{dN}	[Nm]	8.0	7.6	6.8	11.5	11.0	9.5	15.0	14.0	11.9	18.0	16.9	13.7
Rated current	I_{dN}	[A]	3.3	4.0	4.6	5.1	6.0	6.7	6.1	7.3	8.0	7.4	8.8	9.6
Rated speed	n_N	[min ⁻¹]	1500	2000	3000	1500	2000	3000	1500	2000	3000	1500	2000	3000
Rated power	P_{dN}	[kW]	1.3	1.6	2.1	1.8	2.3	3.0	2.4	2.9	3.8	2.8	3.5	4.3
Voltage constant ¹⁾	k_e	[V/1000min ⁻¹]	150	118	90.3	138	112	86.9	151	117	91.0	150	118	87.9
Winding resistance ²⁾	R_{u-v}	[Ω]	8.0	4.9	3.0	4.0	2.6	1.6	3.2	2.0	1.2	2.4	1.5	0.9
Winding inductance	L_{u-v}	[mH]	35.0	21.5	12.7	19.0	12.6	7.5	15.3	9.2	5.6	9.4	5.8	3.2

Max. values

Max. torque	M_{max}	[Nm]	25			36			47			57		
Max. current (peak value)	I_{max}	[A]	12.1	15.5	20.1	19.0	23.3	30.1	22.7	29.4	37.7	27.2	35.3	47.4
Max. speed	n_{max}	[min ⁻¹]	4500											

Mechanical data ³⁾

Inertia	J_L	[kgcm ²]	7.9			11.2			14.4			19.5		
Weight	m	[kg]	10.0			11.9			14.0			18.0		
Overall length	l_{38}	[mm]	203			233			263			293		

¹⁾ at operating temperature

²⁾ at 20°C

³⁾ with resolver size 15 (X3=R9), without holding brake

Measuring systems (X3):

- A8 ECI/EQI 1300 (Heidenhain)
- I8 ERN 1387 (Heidenhain)
- IR SRS/SRM 50 (Sick-Stegmann)
- IW SKS/SKM 36 (Sick-Stegmann)
- R9 Resolver Size 15 (2- or 6-pole)

Dimensions

Motor type	without holding brake				with holding brake			
	with resolver (R9)		with encoder (A8, I8, IR, IW)		with resolver (R9)		with encoderr (A8, I8, IR, IW)	
	l_{38}	r	l_{38}	r	l_{38}	r	l_{38}	r
DUM6-D1	203	182	245	217	237	216	279	251
DUM6-D2	233	212	275	247	267	246	309	281
DUM6-D3	263	242	305	277	297	276	339	311
DUM6-D4	293	272	335	307	327	306	369	341

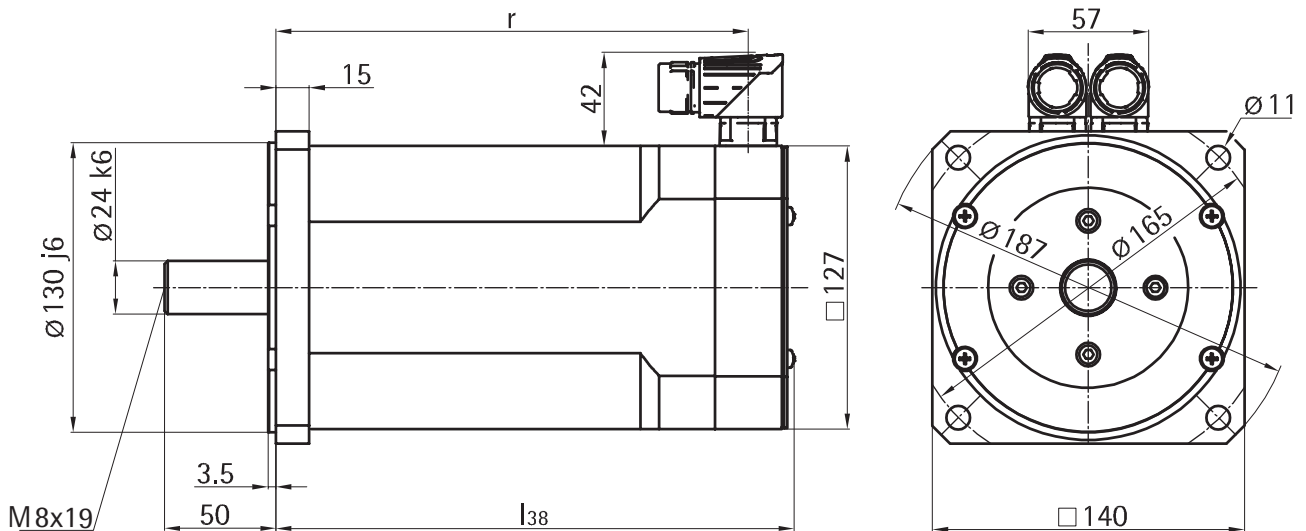

Speed-torque characteristics

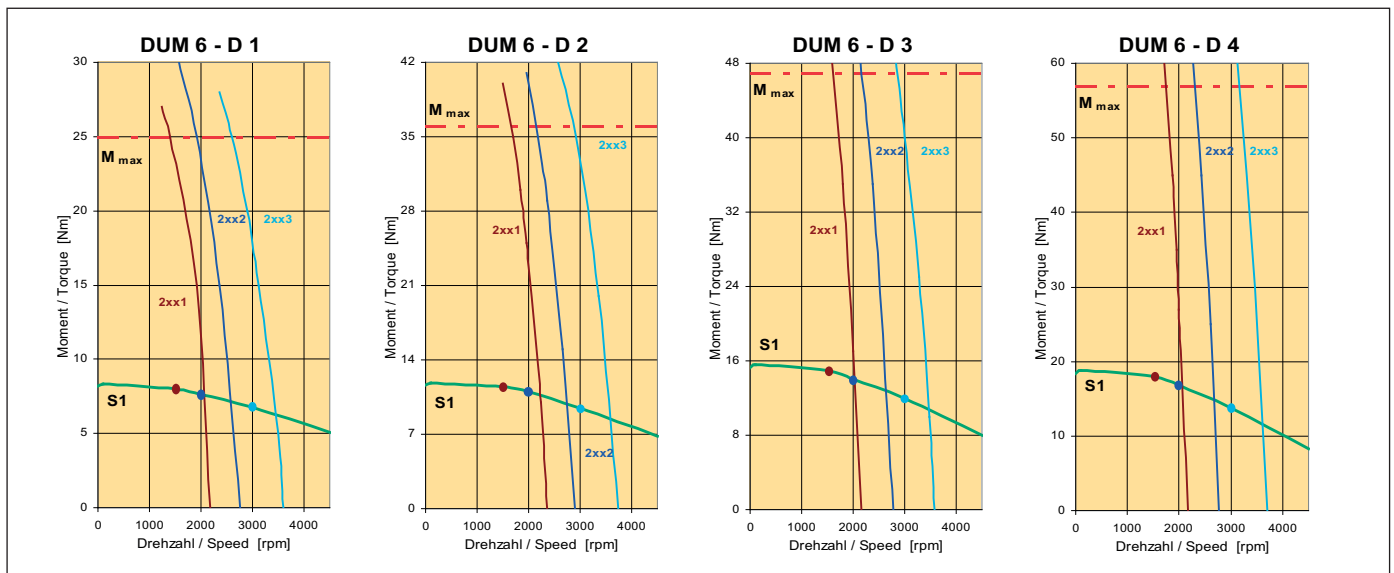

Holding brake

Holding torque	M_{Br}	[Nm]	19
Rated voltage	U_{Br}	[V]	24
Rated current (20°C)	I_{Br}	[A]	0.7
Weight	m	[kg]	1.0
Rotor inertia	J_{Br}	[kgcm ²]	2,95

Technical data DUM 6-E...

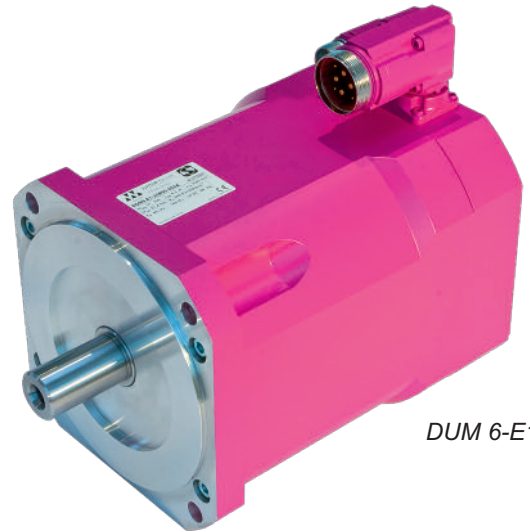

DUM 6-E1

for supply voltages U_N from 400 V

Motor type	DUM 6-E1-			DUM 6-E2-			DUM 6-E3-				
	2xx0	2xx2	2xx3	2xx0	2xx2	2xx3	2xx0	2xx2	2xx3		
Stall torque	M_{d0}	[Nm]	23,5	35,0			48,0				
Current at stall torque	I_{d0}	[A]	7,6	12,7	16,9	10,9	19,3	24,8	16,1	27,7	38,2
Stall torque	M_{d10}	[Nm]	23,7	35,5			48,5				
Current at stall torque	I_{d10}	[A]	7,0	11,7	15,5	10,0	17,7	22,8	14,8	25,4	35,0
Number of poles	2p		8								

Nominal rating

Rated torque	M_{dN}	[Nm]	23	19	14	34	28	19	47	40	27
Rated current	I_{dN}	[A]	6,9	9,7	9,4	9,8	14,2	12,4	14,5	20,8	19,6
Rated speed	n_N	[min ⁻¹]	1000	2000	3000	1000	2000	3000	1000	2000	3000
Rated power	P_{dN}	[kW]	2,4	4,0	4,4	3,6	5,8	6,0	4,9	8,3	8,4
Voltage constant ¹⁾	k_e	[V/1000min ⁻¹]	206,0	120,5	90,4	212,1	119,1	93,0	198,9	116,7	82,5
Winding resistance ²⁾	R_{u-v}	[Ω]	2,31	0,79	0,5	1,42	0,44	0,27	0,87	0,3	0,15
Winding inductance	L_{u-v}	[mH]	38,9	13,3	7,5	26,1	8,2	5,0	17,3	5,9	3,0

Max. values

Max. torque	M_{max}	[Nm]	65			106			145		
Max. current (peak value)	I_{max}	[A]	23,3	39,3	52,2	36,3	64,1	81,7	53,2	90,4	127,0
Max. speed	n_{max}	[min ⁻¹]	4000								

Mechanical data ³⁾

Inertia	J_L	[kgcm ²]	57			79			102		
Weight	m	[kg]	29			34			39		
Overall length	l_{38}	[mm]	266			294			322		

¹⁾ at operating temperature

²⁾ at 20°C

³⁾ with resolver size 15 (X3=R9), without holding brake

Measuring systems (X3):

A8	ECI/EQI 1300 (Heidenhain)
AA	AD 34 (Hengstler)
I8	ERN 1387 (Heidenhain)
IR	SRS/SRM 50 (Sick-Stegmann)
IW	SKS/SKM 36 (Sick-Stegmann)
R9	Resolver Size 15 (2- oder 8-polig)

Dimensions

Motor type	without holding brake				with holding brake			
	with resolver (R9)		with encoderr (A8, AA, I8, IR, IW)		with resolver (R9)		with encoderr (A8, AA, I8, IR, IW)	
	l_{38}	r	l_{38}	r	l_{38}	r	l_{38}	r
DUM6-E1	266	237	293	264	300	271	327	298
DUM6-E2	294	265	321	292	328	299	355	326
DUM6-E3	322	293	349	320	356	327	383	354

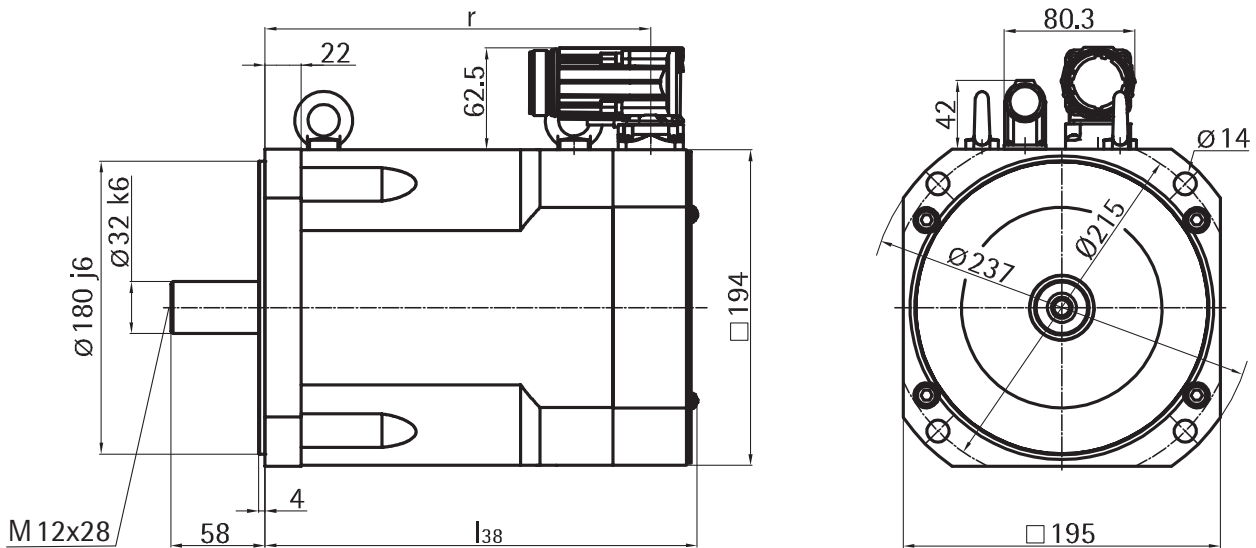

Speed-torque characteristics

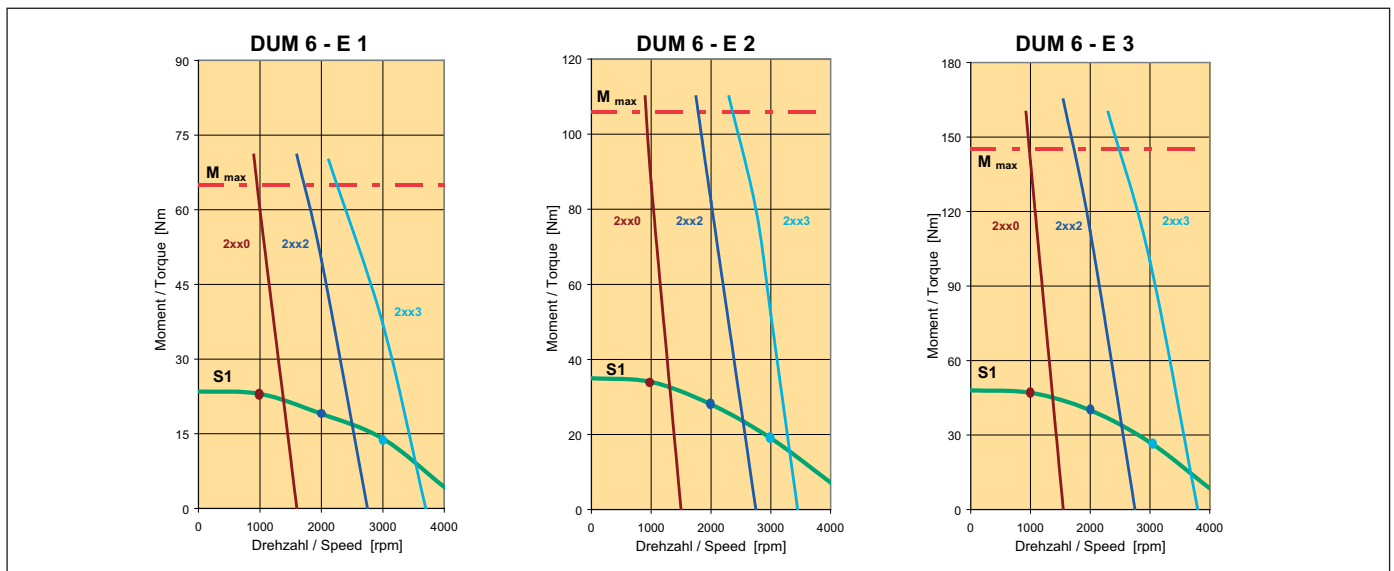

Holding brake

Holding torque	M_{Br}	[Nm]	70
Rated voltage	U_{Br}	[V]	24
Rated current (20°C)	I_{Br}	[A]	1,5
Weight	m	[kg]	3,0
Rotor inertia	J_{Br}	[kgcm ²]	30

Technical data DUF 6-C...

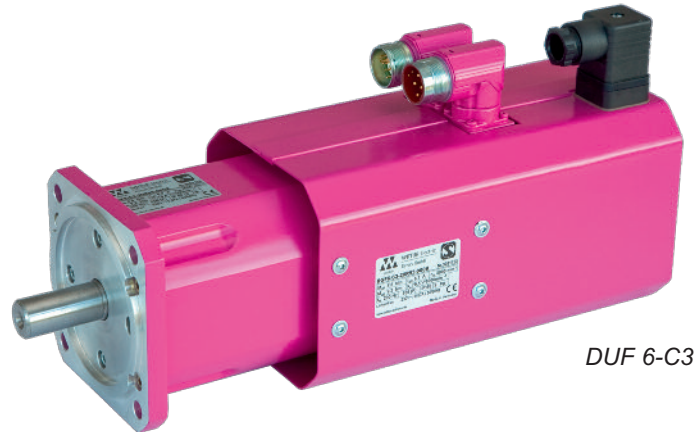

DUF 6-C3

for supply voltages U_N from 400 V

Motor type	DUF 6-C1-			DUF 6-C2-			DUF 6-C3-			DUF 6-C4-					
	2xx2	2xx3	2xx4	2xx2	2xx3	2xx4	2xx2	2xx3	2xx4	2xx2	2xx3	2xx4			
Stall torque	M_{d0}		[Nm]	5.0			7.4			9.2			11.1		
Current at stall torque	I_{d0}		[A]	3.2	4.0	5.0	4.9	6.5	7.9	7.4	9.1	11.4	7.1	11.0	13.7
Stall torque	M_{d10}		[Nm]	52			7.7			9.5			11.4		
Current at stall torque	I_{d10}		[A]	3.3	4.1	5.2	5.0	6.7	8.2	5.9	7.3	9.1	5.6	8.7	10.9
Number of poles	2p			8											

Nominal rating

Rated torque	M_{dN}		[Nm]	5.2	4.7	4.2	7.4	6.4	5.6	9.3	8.6	7.7	11.2	10.3	9.2
Rated current	I_{dN}		[A]	3.3	3.8	4.2	4.9	5.7	6.1	5.8	6.7	7.5	5.7	8.0	8.9
Rated speed	n_N		[min ⁻¹]	2000	3000	4000	2000	3000	4000	2000	3000	4000	2000	3000	4000
Rated power	P_{dN}		[kW]	1.1	1.5	1.8	1.6	2.0	2.4	1.9	2.7	3.2	2.3	3.2	3.8
Voltage constant ¹⁾	k_e		[V/1000min ⁻¹]	98.3	78.9	62.9	92.5	69.4	57.0	97.9	79.5	63.4	122	79.1	63.3
Winding resistance ²⁾	R_{u-v}		[Ω]	11.6	7.4	4.7	6.1	3.6	2.4	4.4	2.9	1.8	5.3	2.2	1.4
Winding inductance	L_{u-v}		[mH]	29.5	19.0	12.1	16.5	9.3	6.3	13.5	8.9	5.7	20.0	8.4	5.4

Max. values

Max. torque	M_{max}		[Nm]	12			17.5			22			26		
Max. current (peak value)	I_{max}		[A]	8.4	10.5	13.2	12.6	16.8	20.4	16.2	20.0	25.1	15.3	23.8	29.6
Max. speed	n_{max}		[min ⁻¹]	6000											

Mechanical data ³⁾

Inertia	J_L		[kgcm ²]	2.7			3.7			4.7			6.0		
Weight	m		[kg]	6.3			7.8			9.0			10.4		
Overall length	l_{39}		[mm]	259			287			315			343		

¹⁾ at operating temperature

²⁾ at 20°C

³⁾ with resolver size 15 (X3=R9), without holding brake

Measuring systems (X3):

- A8 ECI/EQI 1300 (Heidenhain)
- I8 ERN 1387 (Heidenhain)
- IR SRS/SRM 50 (Sick-Stegmann)
- IW SKS/SKM 36 (Sick-Stegmann)
- R9 Resolver Size 15 (2- or 6-pole)

Dimensions

Motor type	without holding brake				with holding brake			
	with resolver (R9)		with encoderr (A8, I8, IR, IW)		with resolver (R9)		with encoderr (A8, I8, IR, IW)	
	l_{39}	r	l_{39}	r	l_{39}	r	l_{39}	r
DUF6-C1	259	158	301	193	295	194	337	229
DUF6-C2	287	186	329	221	323	222	365	257
DUF6-C3	315	214	357	249	351	250	393	285
DUF6-C4	343	242	385	277	379	278	421	313

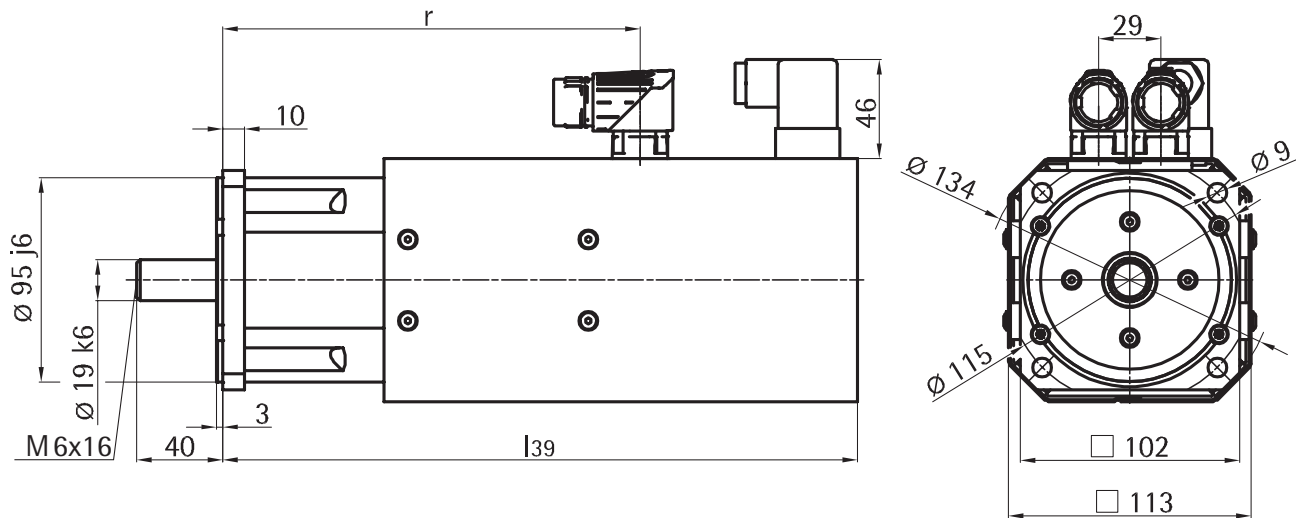

Speed-torque characteristics

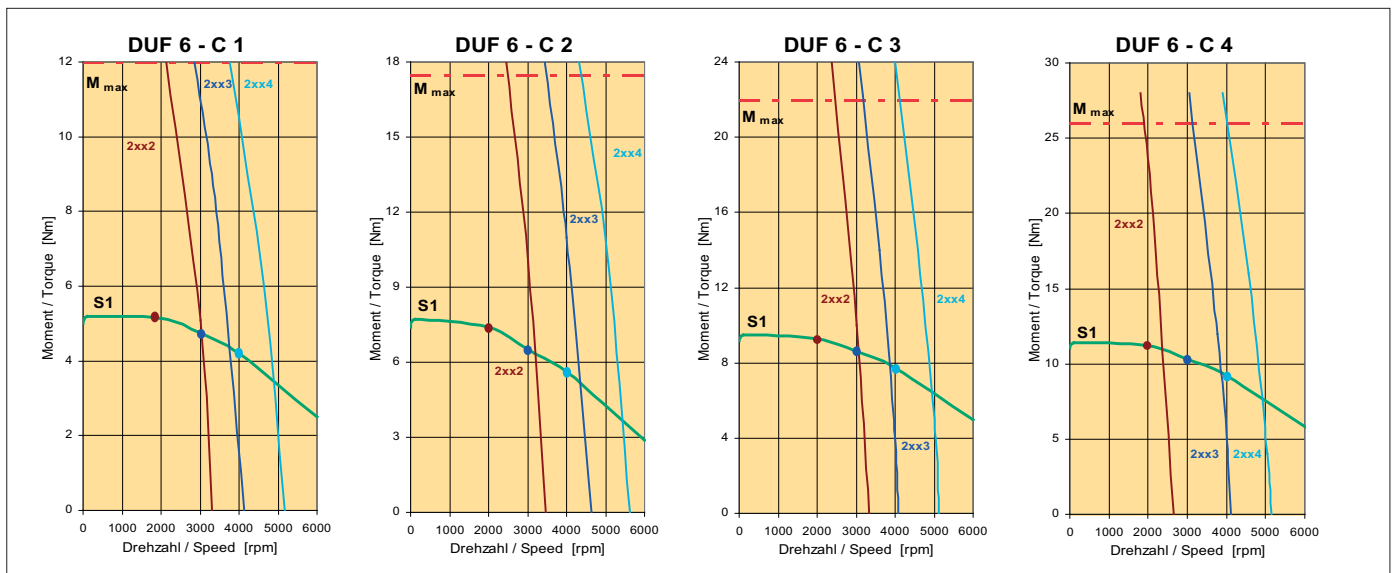

Holding brake

Holding torque	M_{Br}	[Nm]	10
Rated voltage	U_{Br}	[V]	24
Rated current (20°C)	I_{Br}	[A]	0.65
Weight	m	[kg]	0.7
Rotor inertia	J_{Br}	[kgcm ²]	1.07

Technical data DUF 6-D...

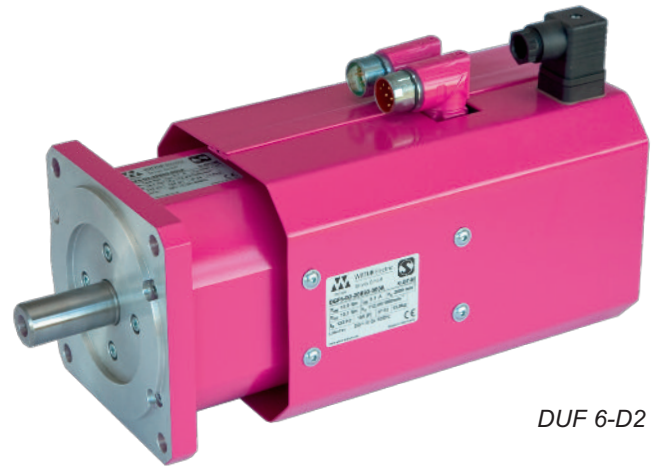

DUF 6-D2

for supply voltages U_N from 400 V

Motor type	DUF 6-D1-			DUF 6-D2-			DUF 6-D3-			DUF 6-D4-					
	2xx1	2xx2	2xx3	2xx1	2xx2	2xx3	2xx1	2xx2	2xx3	2xx1	2xx2	2xx3			
Stall torque	M_{d0}		[Nm]	10.6			15.1			19.9			23.9		
Current at stall torque	I_{d0}		[A]	4.7	6.0	7.9	7.3	9.0	11.6	8.8	11.4	14.6	10.7	13.6	18.2
Stall torque	M_{d10}		[Nm]	11.0			15.6			20.6			24.8		
Current at stall torque	I_{d10}		[A]	4.4	5.6	7.2	6.7	8.2	10.6	8.1	10.5	13.4	9.8	12.5	16.7
Number of poles	2p			8											

Nominal rating

Rated torque	M_{dN}		[Nm]	10.8	10.3	9.1	15.6	14.9	12.8	20.2	18.9	16.1	24.3	22.8	18.5
Rated current	I_{dN}		[A]	4.4	5.4	6.2	6.9	8.1	9.1	8.2	9.9	10.9	9.9	11.9	12.9
Rated speed	n_N		[min ⁻¹]	1500	2000	3000	1500	2000	3000	1500	2000	3000	1500	2000	3000
Rated power	P_{dN}		[kW]	1.7	2.2	2.9	2.4	3.1	4.0	3.2	4.0	5.1	3.8	4.8	5.8
Voltage constant ¹⁾	k_e		[V/1000min ⁻¹]	150	118	90.3	138	112	86.9	151	117	91.0	150	118	87.9
Winding resistance ²⁾	R_{u-v}		[Ω]	8.0	4.9	3.0	4.0	2.6	1.6	3.2	2.0	1.2	2.4	1.5	0.9
Winding inductance	L_{u-v}		[mH]	35.0	21.5	12.7	19.0	12.6	7.5	15.3	9.2	5.6	9.4	5.8	3.2

Max. values

Max. torque	M_{max}		[Nm]	25			36			47			57		
Max. current (peak value)	I_{max}		[A]	12.1	15.5	20.1	19.0	23.3	30.1	22.7	29.4	37.7	27.2	35.3	47.4
Max. speed	n_{max}		[min ⁻¹]	4500											

Mechanical data ³⁾

Inertia	J_L		[kgcm ²]	7.9			11.2			14.4			19.5		
Weight	m		[kg]	11.9			13.8			16.2			20.4		
Overall length	l_{39}		[mm]	285			315			345			375		

¹⁾ at operating temperature

²⁾ at 20°C

³⁾ with resolver size 15 (X3=R9), without holding brake

Measuring systems (X3):

- A8 ECI/EQI 1300 (Heidenhain)
- I8 ERN 1387 (Heidenhain)
- IR SRS/SRM 50 (Sick-Stegmann)
- IW SKS/SKM 36 (Sick-Stegmann)
- R9 Resolver Size 15 (2- or 6-pole)

Dimensions

Motor type	without holding brake				with holding brake			
	with resolver (R9)		with encoderr (A8, I8, IR, IW)		with resolver (R9)		with encoderr (A8, I8, IR, IW)	
	l_{39}	r	l_{39}	r	l_{39}	r	l_{39}	r
DUF6-D1	285	182	327	217	319	216	361	251
DUF6-D2	315	212	357	247	349	246	391	281
DUF6-D3	345	242	387	277	379	276	421	311
DUF6-D4	375	272	417	307	409	306	451	341

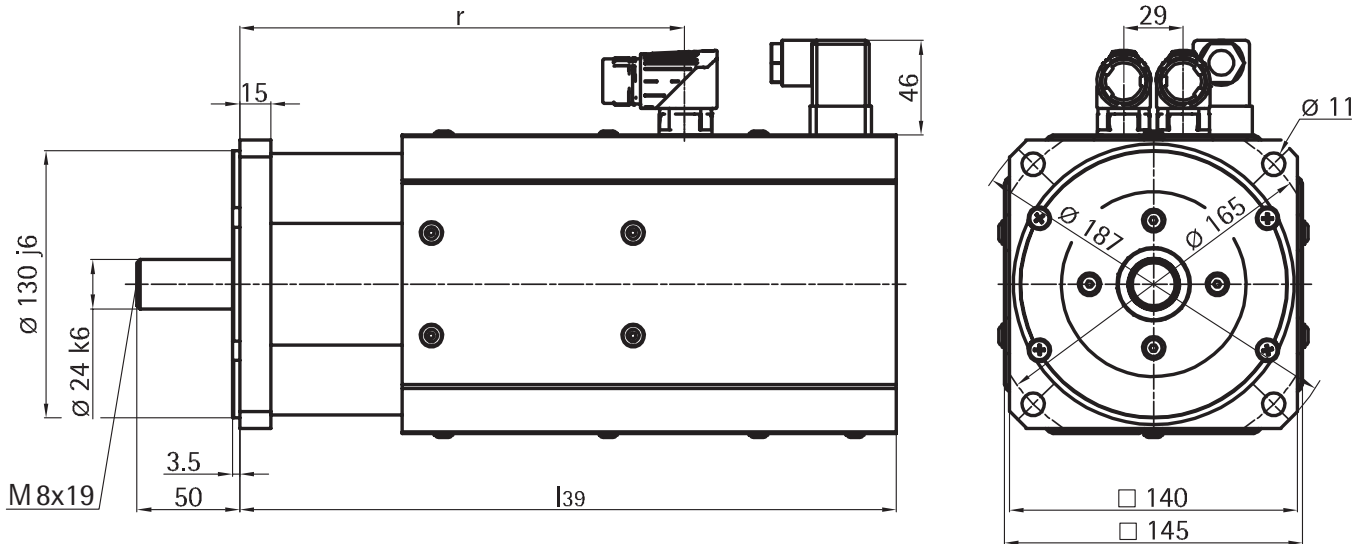

Speed-torque characteristics

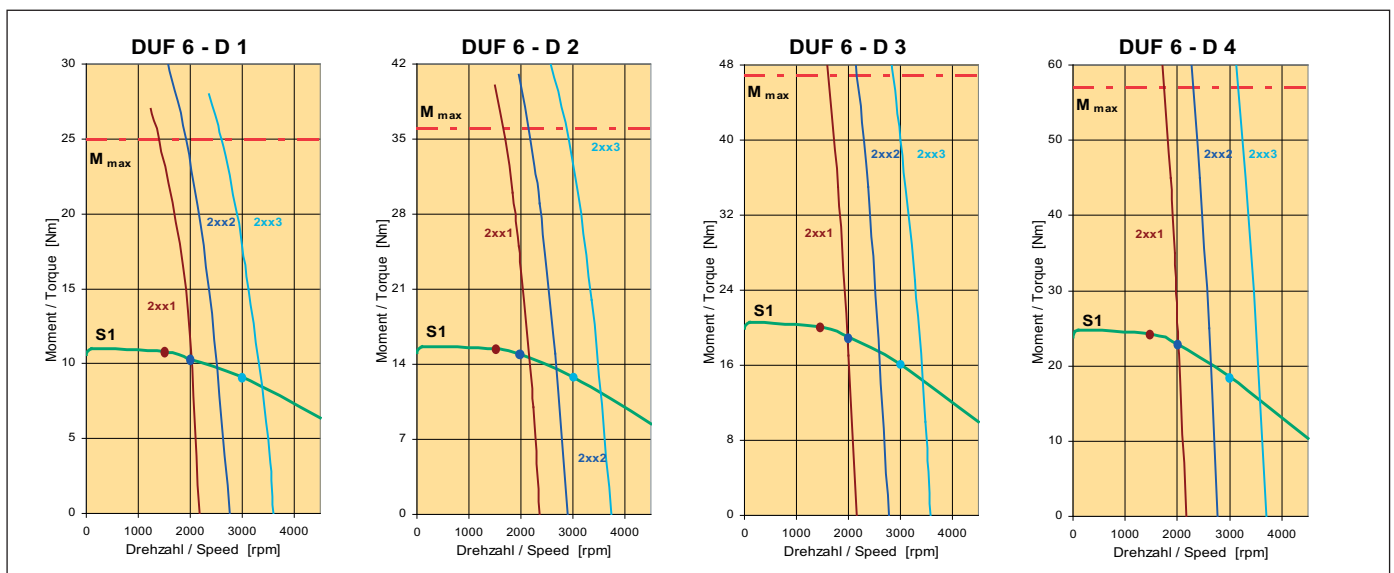

Holding brake

Holding torque	M_{Br}	[Nm]	19
Rated voltage	U_{Br}	[V]	24
Rated current (20°C)	I_{Br}	[A]	0.7
Weight	m	[kg]	1.0
Rotor inertia	J_{Br}	[kgcm ²]	2,95

Technical data DUF 6-E...

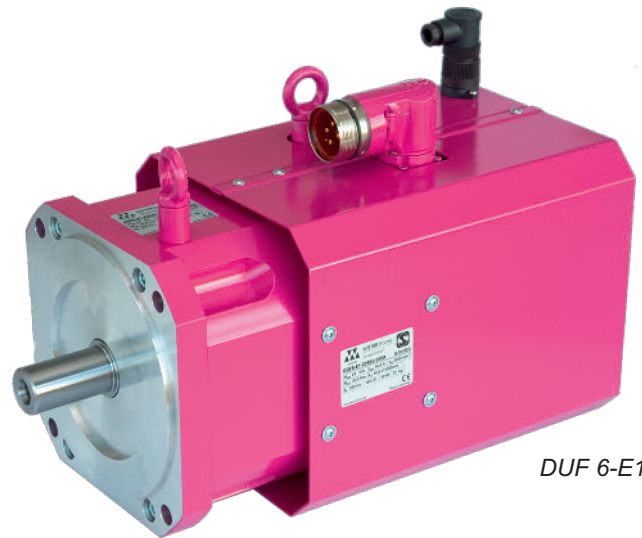

DUF 6-E1

for supply voltages U_N from 400 V

Motor type	DUF 6-E1-			DUF 6-E2-			DUF 6-E3-				
	2xx0	2xx2	2xx3	2xx0	2xx2	2xx3	2xx0	2xx2	2xx3		
Stall torque	M_{d0}	[Nm]	30,6	45,5			62,5				
Current at stall torque	I_{d0}	[A]	9,9	17,1	22,8	14,4	25,5	32,5	21,4	36,9	51,6
Stall torque	M_{d10}	[Nm]	30,8	45,8			63,0				
Current at stall torque	I_{d10}	[A]	9,1	15,1	20,2	13,0	23,0	29,6	19,2	33,0	45,6
Number of poles	2p		8								

Nominal rating

Rated torque	M_{dN}	[Nm]	30	28	24	45	40	34	62	57	48
Rated current	I_{dN}	[A]	9,3	14,4	16,6	13,3	21,0	22,3	19,9	30,8	36,2
Rated speed	n_N	[min ⁻¹]	1000	2000	3000	1000	2000	3000	1000	2000	3000
Rated power	P_{dN}	[kW]	3,1	5,8	7,6	4,7	8,4	10,6	6,5	11,9	15,2
Voltage constant ¹⁾	k_e	[V/1000min ⁻¹]	206,0	120,5	90,4	212,1	119,1	93,0	198,9	116,7	82,5
Winding resistance ²⁾	R_{u-v}	[Ω]	2,31	0,79	0,5	1,42	0,44	0,27	0,87	0,3	0,15
Winding inductance	L_{u-v}	[mH]	38,9	13,3	7,5	26,1	8,2	5,0	17,3	5,9	3,0

Max. values

Max. torque	M_{max}	[Nm]	65			106			145		
Max. current (peak value)	I_{max}	[A]	23,3	39,3	52,2	36,3	64,1	81,7	53,2	90,4	127,0
Max. speed	n_{max}	[min ⁻¹]	4000								

Mechanical data ³⁾

Inertia	J_L	[kgcm ²]	57			79			102		
Weight	m	[kg]	32			37			42		
Overall length	l_{39}	[mm]	380			414			448		

¹⁾ at operating temperature

²⁾ at 20°C

³⁾ with resolver size 15 (X3=R9), without holding brake

Measuring systems (X3):

- A8 ECI/EQI 1300 (Heidenhain)
- AA AD 34 (Hengstler)
- I8 ERN 1387 (Heidenhain)
- IR SRS/SRM 50 (Sick-Stegmann)
- IW SKS/SKM 36 (Sick-Stegmann)
- R9 Resolver Size 15 (2- oder 8-polig)

Dimensions

Motor type	without holding brake				with holding brake			
	with resolver (R9)		with encoderr (A8, AA, I8, IR, IW)		with resolver (R9)		with encoderr (A8, AA, I8, IR, IW)	
	l_{39}	r	l_{39}	r	l_{39}	r	l_{39}	r
DUF6-E1	380	237	407	264	414	271	441	298
DUF6-E2	408	265	435	292	442	299	469	326
DUF6-E3	436	293	463	320	470	327	497	354

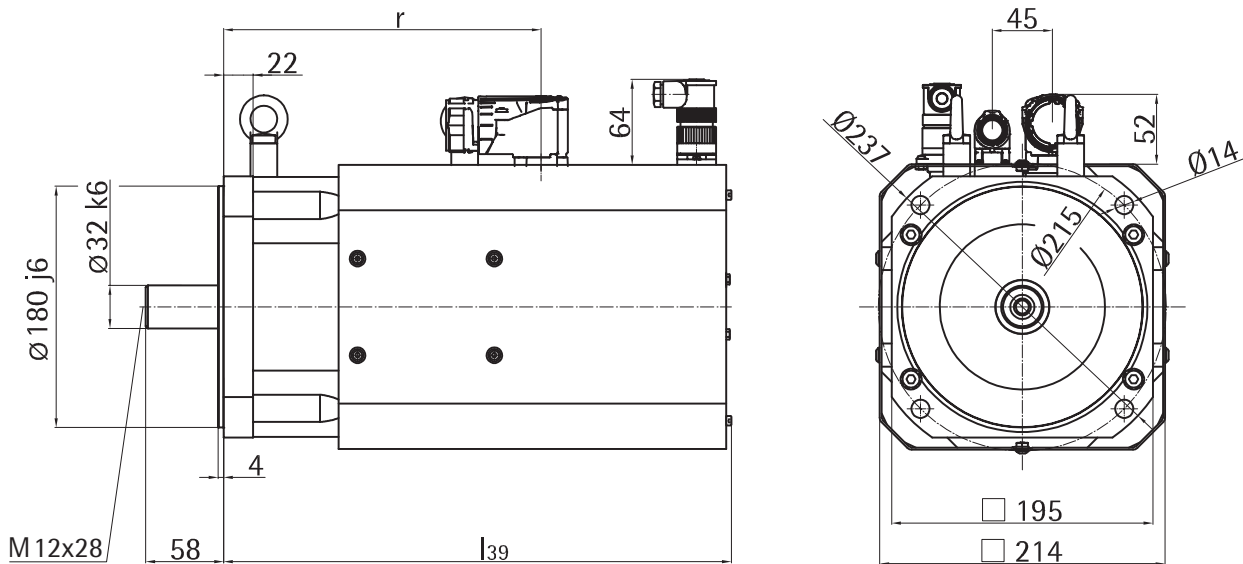

Speed-torque characteristics

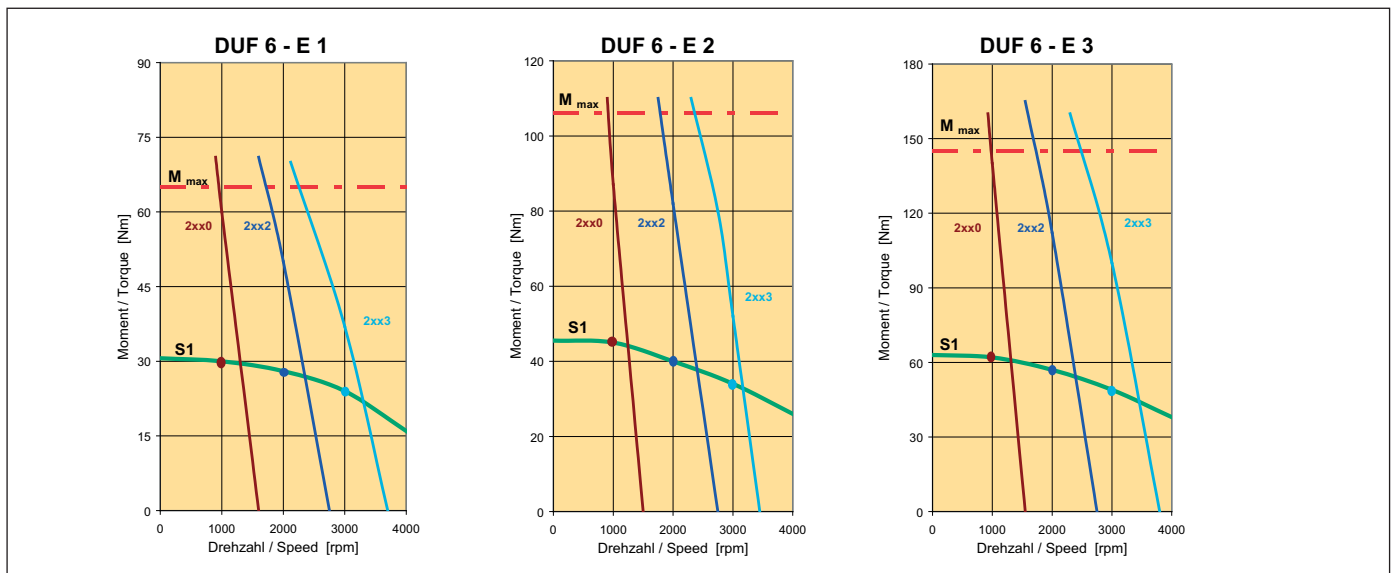

Holding brake

Holding torque	M_{Br}	[Nm]	70
Rated voltage	U_{Br}	[V]	24
Rated current (20°C)	I_{Br}	[A]	1,5
Weight	m	[kg]	3,0
Rotor inertia	J_{Br}	[kgcm ²]	30



WITTUR Electric
Drives GmbH



Offenburger Str. 3
D-01189 Dresden
Germany

Tel. +49(0)3 51-40 44-0
Fax +49(0)3 51-40 44-1 11

info@wittur-edrives.de
www.wittur-edrives.de